

# Industrial Panel Mount LCD

Industrial LCD Monitor - with Aluminum Front Bezel

IP65 Front Panel Mount (Aluminum-10mm), 15.6" / 1366x768 / 1000nits / Aluminum Front Bezel / Flat design / Front IP65 / 6mm Tempered Glass / Projected Touch Screen (USB)(2 point in Win7) / VGA +DVI+ HDMI / Panel mount / VESA mount



1000 nits

**Model: YPMW1560IPHB-PCAP-VR-V2**

## FEATURES:

- Modularize mechanical design provides flexible product configuration and easy maintenance
- Power Optional build-in touch screen for interactive application.
- Complete custom design/solution for OEM customers
- External OSD Box "Up" and "Down" to Control Brightness directly.

## SYSTEM SPECIFICATIONS:

<b>Panel</b>	Cell Type / Glass Surface	TFT LCD / Black Anti-Glare, low reflection coating	
	Aspect Ratio / Size	Wide / 15.6" viewable diagonal area	
	Active Area / Pixel Pitch	344.2(H) x 193.56(V) mm / 0.2588(H) x 0.2588(V) mm	
	Native Resolution / Colors	1366(H) x 768(V) / 16.7M	
	Brightness / Contrast	1000 cd/m <sup>2</sup> (typ) / 500 : 1	
	Response Time	≤ 8 ms	
	Viewing Angle (typical)	85/85/80/80	
Light Source	LED backlight, Long life, 50,000 hrs (typ)		
<b>Input Sources</b>	PC System	Signal	Analog RGB (0.7/1.0 V <sub>p-p</sub> , 75 ohms)
		Sync	Separate Sync, Composite Sync, Sync On Green
		Frequency	F <sub>h</sub> : 30 - 82Khz , F <sub>v</sub> : 50 - 75Hz
	Audio System	Optional	
<b>Input Terminals</b>	VGA, DVI, HDMI, 1 x PC Audio (Stereo Headphone Jack) , 1 x DC Power Plug		
<b>Convenient Features</b>	Auto Calibration , Back Light Adjustment , Plug&Play (VESA DDC/CI, DDC 2B)		
	OSD Multi-Languages , Wall Mount Ready (VESA Dimension - please refer to Drawing)		
<b>Power</b>	Internal power supply with universal / Auto-Sensing, AC90 to 260V, 50/60 Hz		
<b>Power Consumption</b>	Operation / Power Saving	20 Watts	
<b>Operating Condition</b>	Temperature / Humidity	0°C ~ 50°C (32°F ~ 122°F) , 10% ~ 90% (no condensation)	
<b>Storage Condition</b>	Temperature / Humidity	- 20°C ~ 60°C (- 4°F ~ 140°F) , 10% ~ 90% (no condensation)	
<b>Dimensions</b>	Physical	Please refer to Drawing	
	Carton	W x H x D = TBD	
<b>Weight</b>	N.W. / G.W.	6 Kgs / 7 Kgs	
<b>Container Loaded</b>	20ft / 40ft / 40ft HQ	TBD (Sets , By pallet)	

\*Specifications subject to change without notice, not responsible for typographical errors.

# MECHANICAL DRAWING:

This is subject to change without Notice. Final Drawings Will be Provided for Approval after Order.

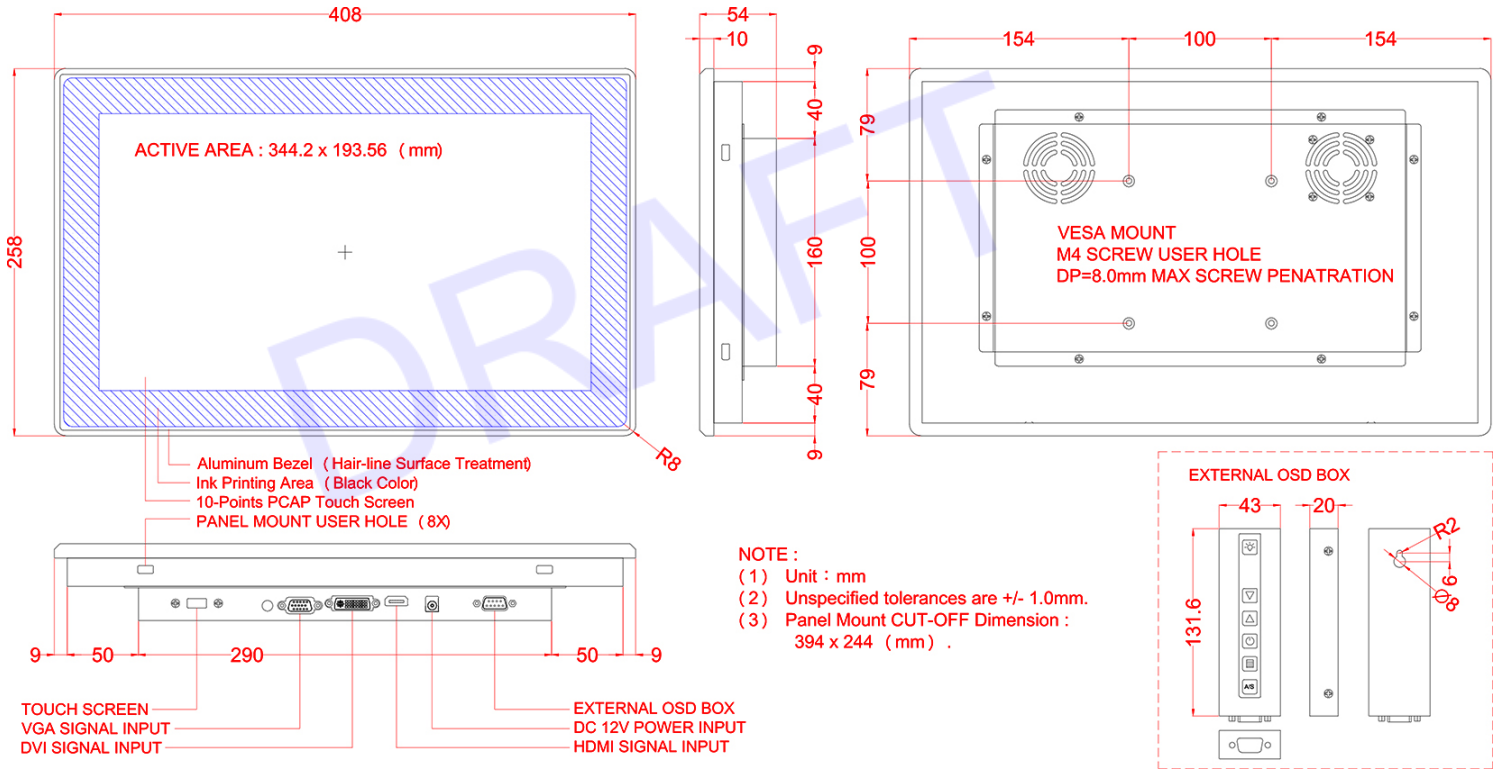

Drawing No.: YPMW1560IPHB-PCAP-VR-V2-06142023-V1

## FLAT DESIGN

