

DUAL DISPLAY RACKMOUNT MONITOR

Dual Display Rack Mount w 7" LCD Monitor, 1024x600
LED-200nits, VGA, HDMI, DP, 12VDC-IN w/ Adapter

MODEL: ERM2DW700X-H



FEATURES HIGHLIGHTS:

- Modularize mechanical design provides flexible product configuration and easy maintenance
- Optional build-in touch screen for interactive application
- Available with auto-brightness sensor offers application in day and night
- VGA connector with optional AV.SV.AV-Looping
- Complete custom design/solution for OEM customers
- Auto Power On: Monitor is always "ON" when connect to power.
- Auto Video Signal On: Monitor (Backlight) will turn off when no video signal, but it will Auto turn back on.

SPECIFICATIONS:

Panel	Cell Type / Glass Surface	TFT LCD / Black Anti-Glare, low reflection coating	
	Aspect Ratio / Size	Wide / 7" viewable diagonal area	
	Active Area / Pixel Pitch	153.60(H) x 90(V) mm / 0.150(H) x 0.150(V) mm	
	Native Resolution / Colors	1024(H) x600(V) / 262 K	
	Brightness / Contrast	200 cd/m ² (typ) / 700 : 1	
	Response Time	< 16 ms	
	Viewing Angle (typical)	H. 150° (- 75° ~ + 75°) , V. 140°(- 75° ~ + 65°)	
	Light Source	LED backlight, Long life, 35,000 hrs (typ)	
Input Sources	PC System	Signal	Analog RGB (0.7/1.0 V _{p-p} , 75 ohms)
		Sync	Separate Sync, Composite Sync, Sync On Green
		Frequency	F _h : 30 - 82Khz , F _v : 50 -75Hz
	Audio System	2W Speaker	
Input Terminals	VGA + HDMI +DP		
Convenient Features	Auto Calibration , Back Light Adjustment, Plug&Play (VESADDC/CI, DDC 2B)		
	OSD Multi-Languages , Wall Mount Ready (VESA Dimension - please refer to Drawing)		
Power	12V DC in		
Power Consumption	Operation / Power Saving	9.625 watt, < 2 watt (Support DPMS)	
Operating Condition	Temperature / Humidity	0°C ~ 50°C (32°F ~ 122°F) , 10% ~ 90% (no condensation)	
Storage Condition	Temperature / Humidity	- 20°C ~ 60°C (- 4°F ~ 140°F) , 10% ~ 90% (no condensation)	
Certification	FCC,CE		
Dimensions	Physical	Please refer to Drawing	
	Carton	WxHxD=TBD	
Weight	N.W./G.W.	3 Kgs/4 Kgs	
Container Loaded	20ft / 40ft / 40ft HQ	TBD (Sets , By pallet)	

Options	Touch	Video/TV	Enhanced Panel	Others
	Resistive touch	SV + AV	Panel with LED backlight	Digital Signage(Stand alone)
	Capacitive touch	SV + AV + AV Looping	High brightness panel	Networking Digital Signage
	SAW touch	SV + AV + TV	Wide Temperature	Motion Sensor
	Infrared touch		Sunlight Readable	Light Sensor
	Protected glass			Auto-Dimming

*Specifications subject to change without notice, not responsible for typographical errors.

Modified: 05-16-2022

MECHANICAL DRAWING:

This is subject to change without Notice. Final Drawings Will be Provided for Approval after Order.

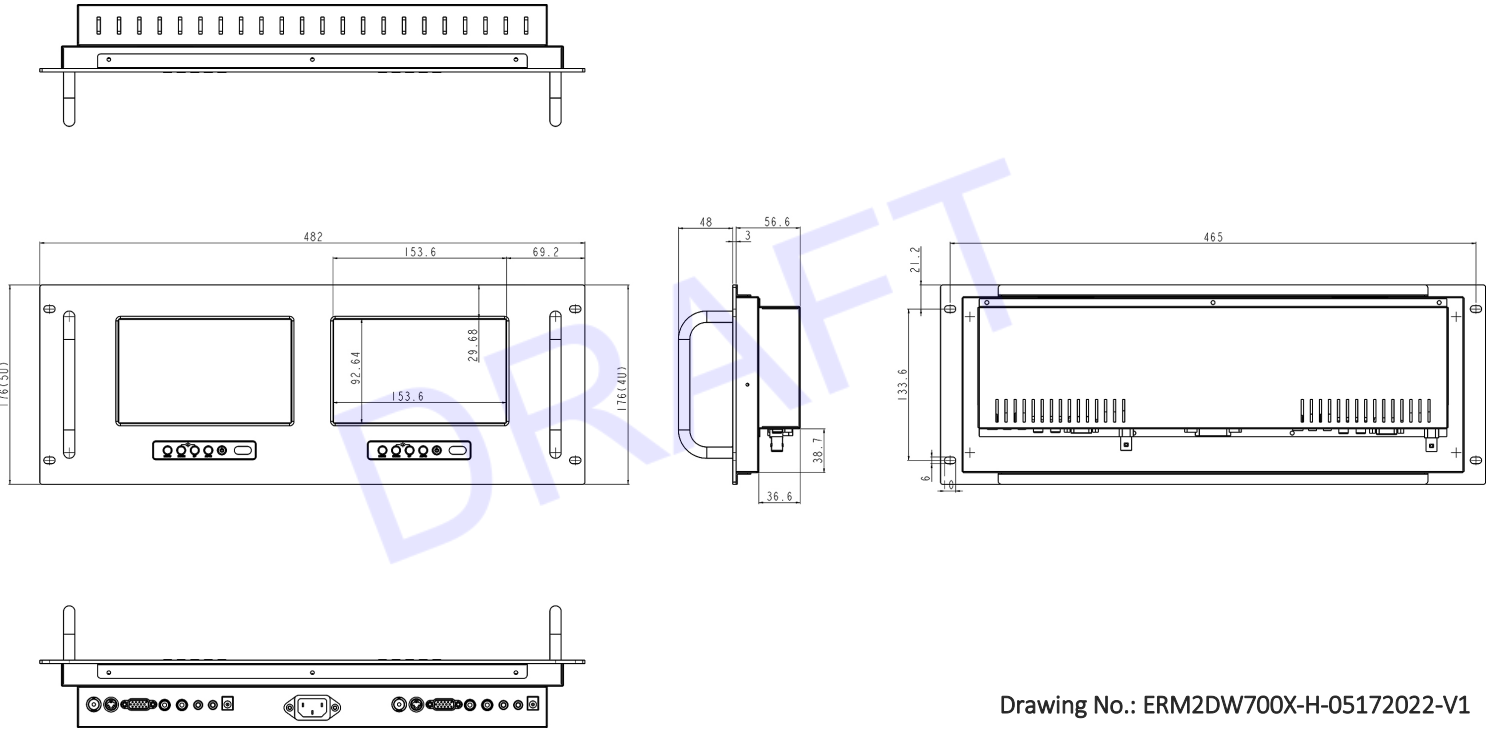

Drawing No.: ERM2DW700X-H-05172022-V1