



MIL STD 461E/ F

TEST REPORT

For

20.1 Multimedia LCD Monitor

Model Number:

WMRM920-PIP

Trade Name: iTech

Issued to

**iTech Company LLC
41758 Christy Street,
Fremont CA 94538 USA**

Issued by

**Compliance Certification Services Inc.
No. 11, Wugong 6th Rd., Wugu Industrial Park
Taipei Hsien 248, Taiwan
<http://www.ccsemc.com.tw>
service@tw.ccsemc.com**

***Note:** This report shall not be reproduced except in full, without the written approval of Compliance Certification Services Inc. This document may be altered or revised by Compliance Certification Services Inc. personnel only, and shall be noted in the revision section of the document.*



TABLE OF CONTENTS

1. TEST RESULT CERTIFICATION	3
2. EUT DESCRIPTION.....	4
3. TEST METHODOLOGY.....	5
4. INSTRUMENT AND CALIBRATION.....	5
4.1 MEASURING INSTRUMENT CALIBRATION	5
4.2 MEASUREMENT EQUIPMENT USED	5
5. FACILITIES AND ACCREDITATIONS.....	6
5.1 FACILITIES	6
6. SETUP OF EQUIPMENT UNDER TEST.....	7
6.1 SETUP CONFIGURATION OF EUT	7
6.2 SUPPORT EQUIPMENT	7
6.3 TEST SETUP	7
7. MIL STD 461E/F REQUIREMENTS	8
7.1 CS101, CONDUCTED SUSCEPTIBILITY, POWER LEADS, 30 HZ TO 150 KHZ	8
8. APPENDIX I PHOTOGRAPHS OF TEST SETUP	35



1. TEST RESULT CERTIFICATION

Applicant: iTech Company LLC
41758 Christy Street, Fremont CA 94538 USA

Equipment Under Test: 20.1 Multimedia LCD Monitor

Trade Name: iTech

Model Number: WMRM920-PIP

Date of Test: July 6, 2009

APPLICABLE STANDARDS	
STANDARD	TEST RESULT
MIL STD 461E/F	No non-compliance noted
Applicable Standard	Test Result
MIL STD 461E/F	
CS101: Conducted susceptibility, power leads, 30 Hz to 150 kHz.	No non-compliance noted
Deviation from Applicable Standard	
N/A	

The above equipment was tested by Compliance Certification Services Inc. for compliance with the requirements set forth in MIL STD 461E/F. The results of testing in this report apply only to the product/system, which was tested. Other similar equipment will not necessarily produce the same results due to production tolerance and measurement uncertainties.

Approved by:

Reviewed by:

James Lee
Section Manager
Compliance Certification Services Inc.

Bruce Chen
Senior Engineer
Compliance Certification Services Inc.



2. EUT DESCRIPTION

Product	20.1 Multimedia LCD Monitor
Trade Name	iTech
Model Number	WMRM920-PIP
Model Discrepancy	
EUT Power Rating	MB: iTech/ R2A Panel LCD: 20.1 AUO / M201UN02-V6 Power Board: Wearnes/ WDS080121 RS232 Port: Link PC /Touch

Remark: for more details, please refer to the User's manual of the EUT.



3. TEST METHODOLOGY

All tests were performed in accordance with the procedure documented in MIL STD 461F.

4. INSTRUMENT AND CALIBRATION

4.1 MEASURING INSTRUMENT CALIBRATION

The measuring equipment, which was utilized in performing the tests documented herein, has been calibrated in accordance with the manufacturer’s recommendations for utilizing calibration equipment, which is traceable to recognized national standards.

4.2 MEASUREMENT EQUIPMENT USED

Equipment Used for Emissions Measurement

CS101 (844 Chamber)				
Name of Equipment	Manufacturer	Model	Serial Number	Calibration Due
Continuous Wave Simulator	EM-TEST	CWS 500E	V0606101158	10/01/2010
Software	ICD 3.53			



5. FACILITIES AND ACCREDITATIONS

5.1 FACILITIES

All measurement facilities used to collect the measurement data are located at

No.199, Chunghsen Road, Hsintien City, Taipei Hsien, Taiwan, R.O.C.

Tel: 886-2-2217-0894 / Fax: 886-2-2217-1029

No.11, Wugong 6th Rd., Wugu Industrial Park, Taipei Hsien 248, Taiwan

Tel: 886-2-2299-9720 / Fax: 886-2-2299-9721

No.81-1, Lane 210, Bade 2nd Rd., Luchu Hsiang, Taoyuan Hsien 338, Taiwan

Tel: 886-3-324-0332 / Fax: 886-3-324-5235

The sites are constructed in conformance with the requirements of ANSI C63.7, ANSI C63.4 and CISPR Publication 22.



6. SETUP OF EQUIPMENT UNDER TEST

6.1 SETUP CONFIGURATION OF EUT

See test photographs attached in Appendix 1 for the actual connections between EUT and support equipment.

6.2 SUPPORT EQUIPMENT

No.	Device Type	Brand	Model	Series No.	FCC ID	Data Cable	Power Cord
1	Notebook PC	DELL	PP19L	GH645 A03	E2KWM3945ABG	N/A	N/A

Remarks:

- 1. All the above equipment/cables were placed in worse case positions to maximize emission signals during emission test.*
- 2. Grounding was established in accordance with the manufacturer's requirements and conditions for the intended use.*

6.3 TEST SETUP

The equipment under test was configured in normal operation continuously. EUT tends to maximize its emission characteristics in a typical application for immunity test. The EUT was active during the immunity test measurements.

7. MIL STD 461E/F REQUIREMENTS

7.1 CS101, conducted susceptibility, power leads, 30 Hz to 150 kHz

LIMIT

The EUT shall not exhibit any malfunction, degradation of performance, or deviation from specified indications, beyond the tolerances indicated in the individual equipment or subsystem specification, when subjected to a test signal with voltage levels as specified in Figure CS101-1. The requirement is also met when the power source is adjusted to dissipate the power level shown in Figure CS101-2 in a 0.5 ohm load and the EUT is not susceptible.

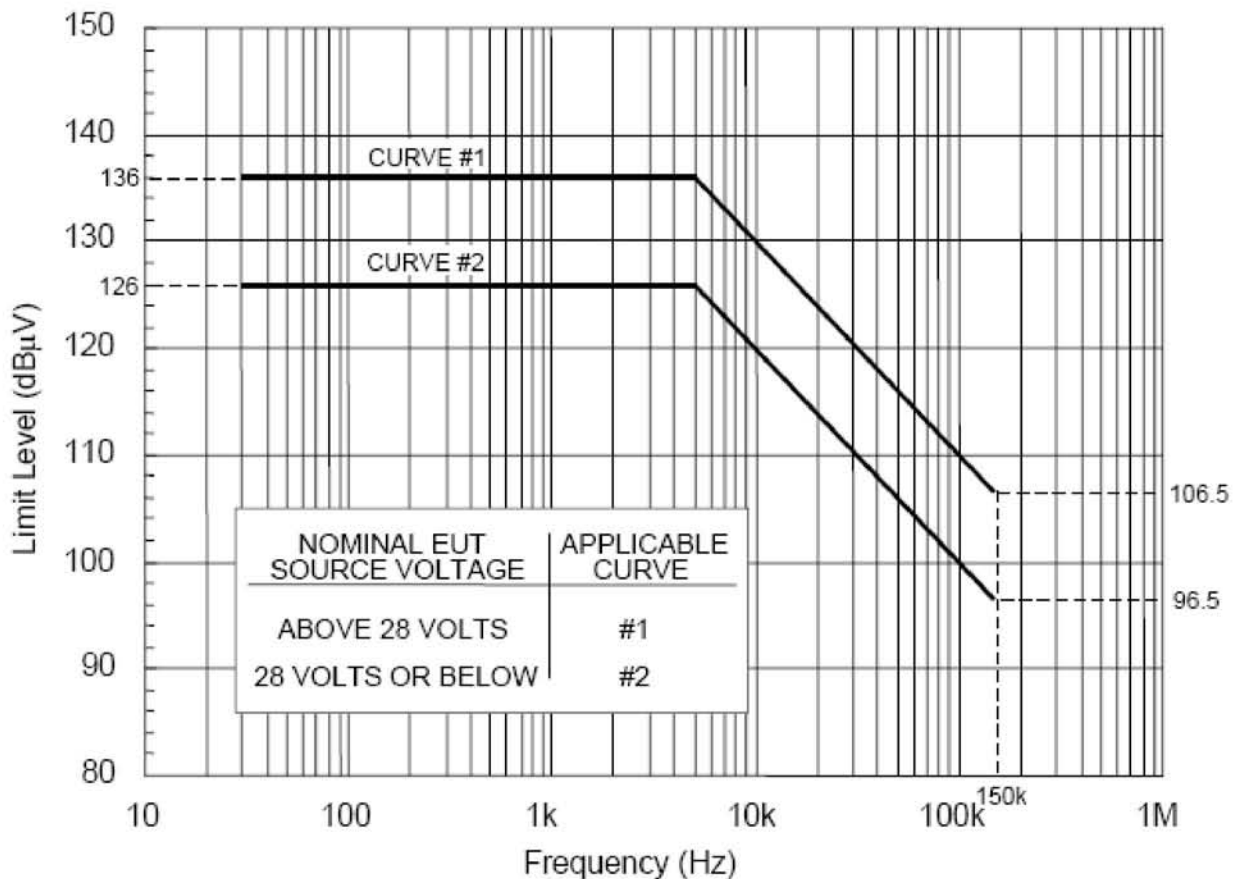

FIGURE CS101-1. CS101 voltage limit for all applications.

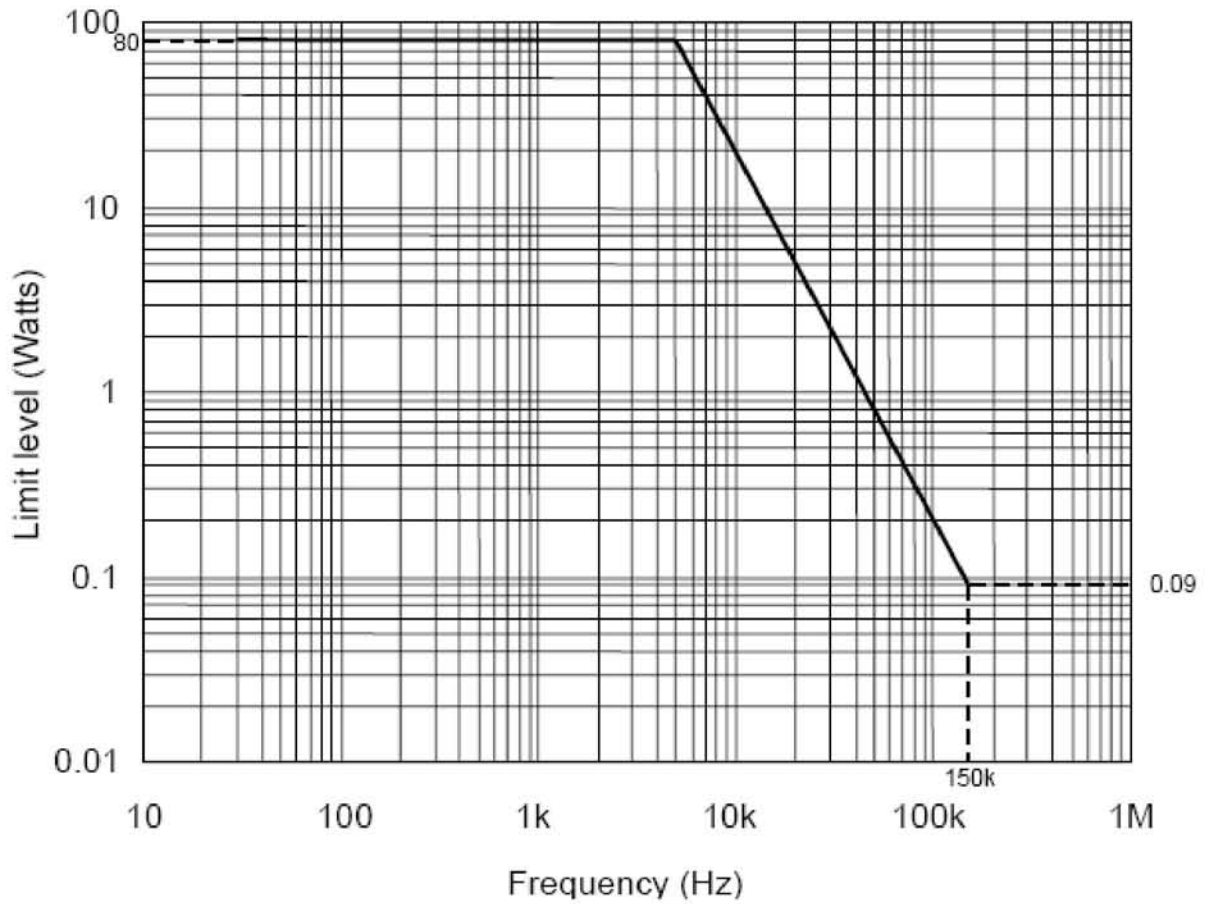

FIGURE CS101-2. CS101 power limit for all applications.



CLASSIFICATION OF FUNCTIONAL STATUS

All classifications are for the total device/system functional status.

Class A: all functions of a device/system perform as designed during and after exposure to disturbance.

Class B: all functions of a device/system perform as designed during exposure. However, one or more of them can go beyond specified tolerance. All functions return automatically to within normal limits after exposure is removed.

Class C: one or more functions of a device/system do not perform as designed during exposure but return automatically to normal operation after exposure is removed.

Class D: one or more functions of a device/system do not perform as designed during exposure and do not return to normal operation until exposure is removed and the device/system is reset by simple “operator/use” action.

Class E: one or more functions of a device/system do not perform as designed during and after exposure and cannot be returned to proper operation without repairing or replacing the device/system.

NOTE: The word “function” in this context refers only to the function performed by the electronic system.

TEST CONFIGURATION

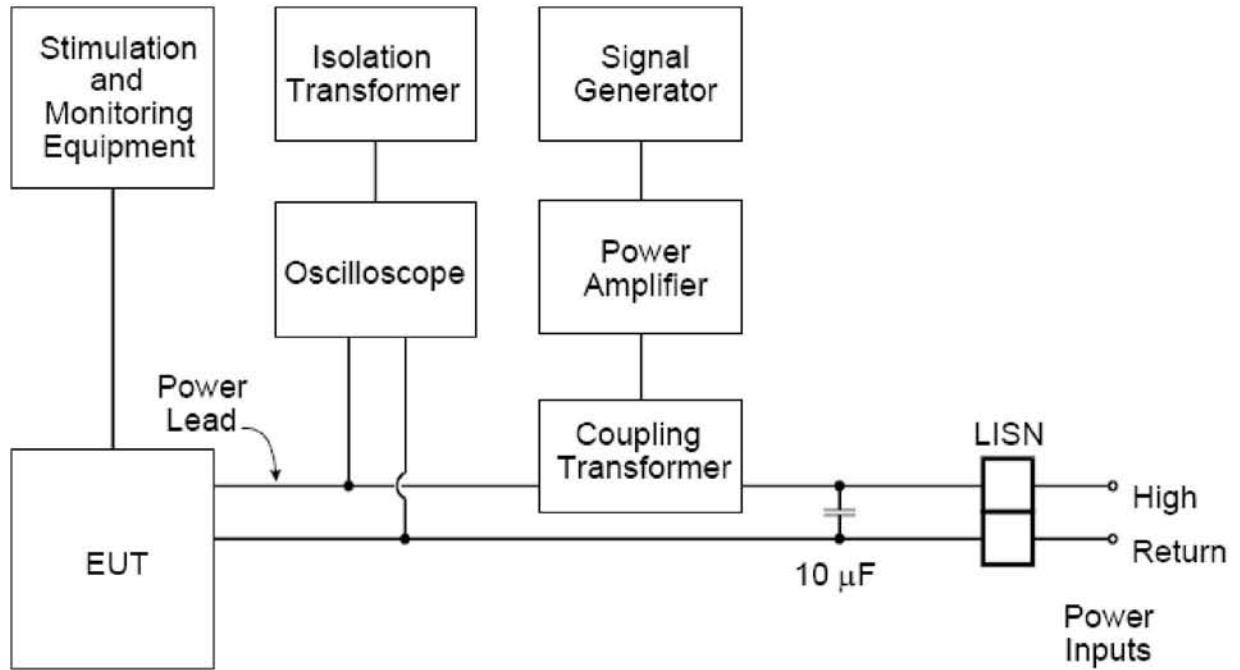

FIGURE CS101-4. Signal injection, DC or single phase AC

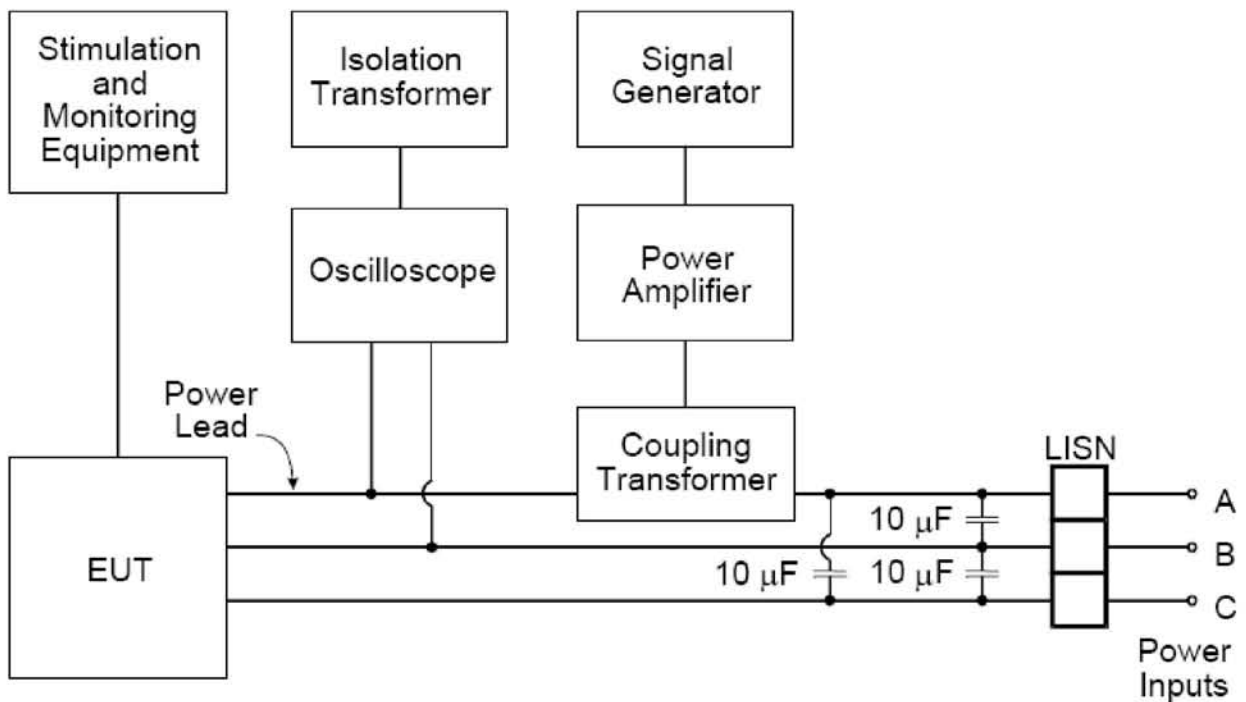

FIGURE CS101-5. Signal injection, 3-phase ungrounded.

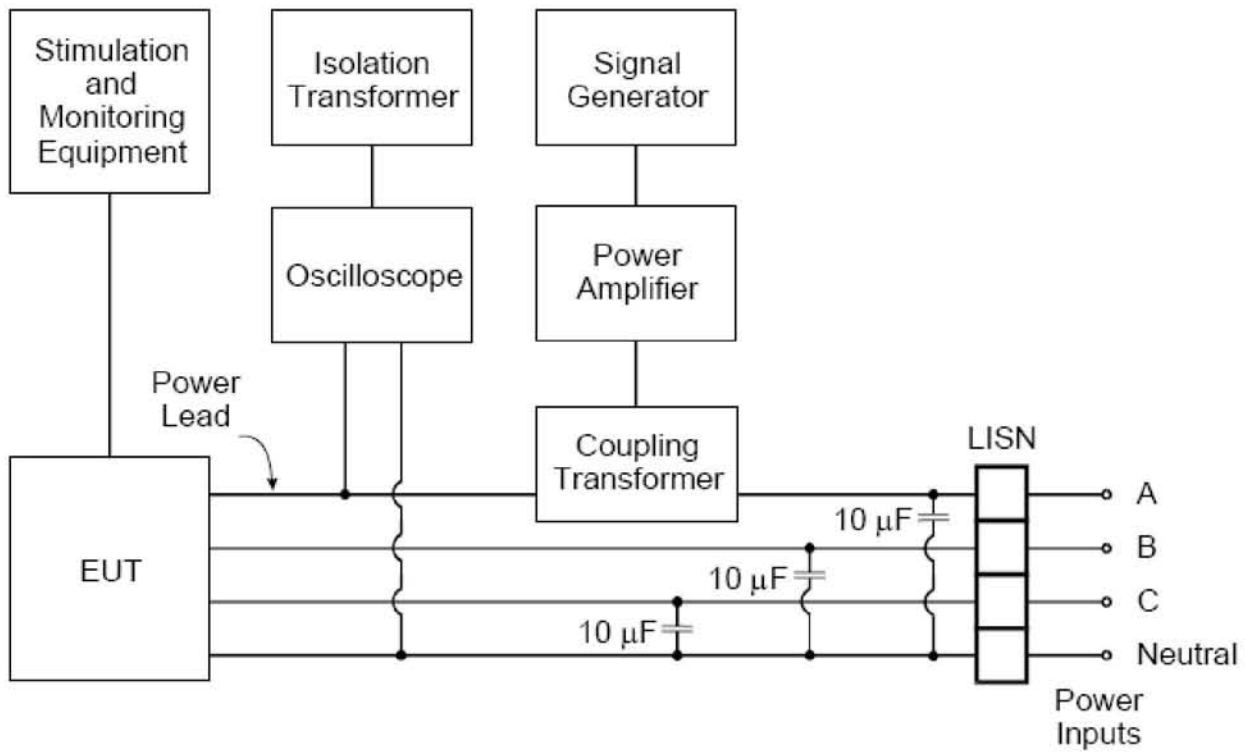

FIGURE CS101-6. Signal injection, 3-phase wye.

TEST PROCEDURE

The magnetic emission of EUT representative of its type shall be tested by the method(s) according to MIL STD 461E/F.



TEST RESULTS

No non-compliance noted

Test Data

Test Sequence	EUT Power (Vac)	Test Curve(#)	Test Result	Remark
L1	110	1	A	Normal function
L2	110	1	A	Normal function
L3	110	1	A	Normal function



L1 to L2 test data:

Test center CCS

TEST REPORT

Report No. : 90626003

Standard MIL STD-461E/F CS101
 Test object 20.1 Multimedia LCD Monitor
 WMRM920-PIP
 Customer iTech Company LLC
 Test engineer Eric
 Recorded July 6, 2009 3:57:54 pm , with ICD 3.50.11
 Test equipment 1.) EM TEST AG, CWS 500E, RE9E0E9Q9A
 Result file C:\EMTEST\ICD350\RESULT\11.prj
 Description Class : A
 Result Test passed

Testfile

Name curve 1 136dbuv ac 5%.nrm
 Path c:\emtest\icd350\standard\automotive\international\iso\cns
 9589\mil-std-461f\complete\cs101\curve 1 136dbuv ac 5%.nrm

Modification date 2009/7/2 11:48:52

Climatic condition

Temperature 23
 Humidity 54
 Pressure 1020

Test Values

no.	title	F1 [kHz]	L1	F2 [kHz]	L2	F-step [kHz]	td [s]	tp [s]	Modulation
			[dBuV]		[dBuV]				
1.	Curve #1	0.030	136.0	5.000	136.0	5.0 %	3.0 s	0.0 s	CW
2.		5.000	136.0	150.000	106.5	5.0 %	3.0 s	0.0 s	CW



Diagrams

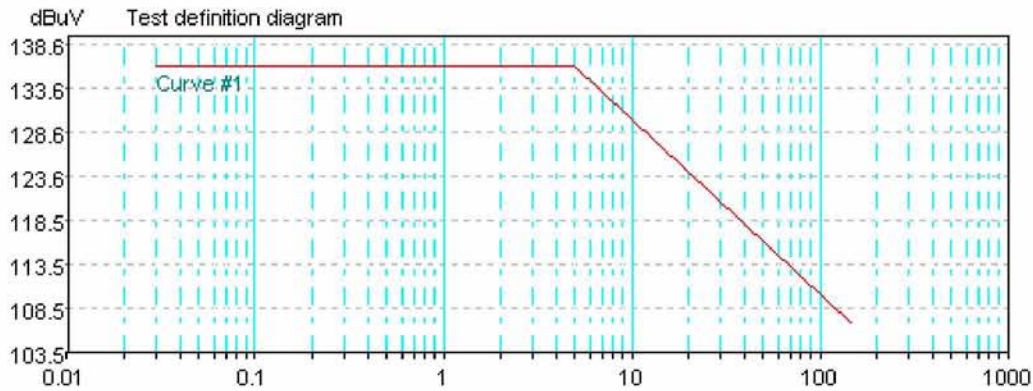

Test summary

no.	Calibration file	Tp. count	Ev. count	passed
1.	Trafo2-1 Curve #1 0_03 - 150_0 kHz, 5_0 %.CAL	176/177	1	no

Coupling device: 1

Model Trafo2-1
Sno
Note 60VAC, 50ADC max
Frequency range 0.010 .. 250.000 kHz
Coupling port DC-Port
description

Diagrams

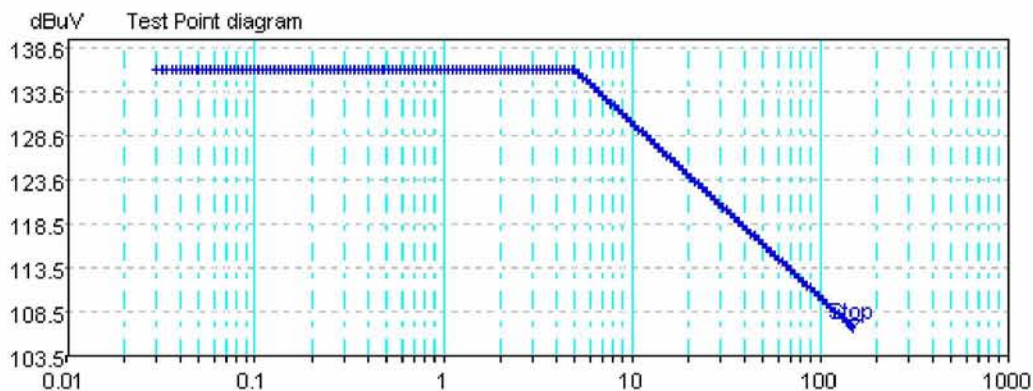



Table of events : 1

no.	Events	Frequency [kHz]	Level [dBuV]	Comment
1	Stop	150.000	106.5	

Table of Test points : 176

no.	Frequency [kHz]	Level [dBuV]
1	0.030	136.0
2	0.032	136.0
3	0.034	136.0
4	0.036	136.0
5	0.038	136.0
6	0.040	136.0
7	0.042	136.0
8	0.044	136.0
9	0.046	136.0
10	0.048	136.0
11	0.050	136.0
12	0.052	136.0
13	0.055	136.0
14	0.058	136.0
15	0.061	136.0
16	0.064	136.0
17	0.067	136.0
18	0.070	136.0
19	0.074	136.0
20	0.078	136.0
21	0.082	136.0
22	0.086	136.0
23	0.090	136.0
24	0.094	136.0
25	0.099	136.0
26	0.104	136.0
27	0.109	136.0
28	0.114	136.0
29	0.120	136.0
30	0.126	136.0



31	0.132	136.0
32	0.139	136.0
33	0.146	136.0
34	0.153	136.0
35	0.161	136.0
36	0.169	136.0
37	0.177	136.0
38	0.186	136.0
39	0.195	136.0
40	0.205	136.0
41	0.215	136.0
42	0.226	136.0
43	0.237	136.0
44	0.249	136.0
45	0.261	136.0
46	0.274	136.0
47	0.288	136.0
48	0.302	136.0
49	0.317	136.0
50	0.333	136.0
51	0.350	136.0
52	0.368	136.0
53	0.386	136.0
54	0.405	136.0
55	0.425	136.0
56	0.446	136.0
57	0.468	136.0
58	0.491	136.0
59	0.516	136.0
60	0.542	136.0
61	0.569	136.0
62	0.597	136.0
63	0.627	136.0
64	0.658	136.0
65	0.691	136.0
66	0.726	136.0
67	0.762	136.0
68	0.800	136.0



69	0.840	136.0
70	0.882	136.0
71	0.926	136.0
72	0.972	136.0
73	1.021	136.0
74	1.072	136.0
75	1.126	136.0
76	1.182	136.0
77	1.241	136.0
78	1.303	136.0
79	1.368	136.0
80	1.436	136.0
81	1.508	136.0
82	1.583	136.0
83	1.662	136.0
84	1.745	136.0
85	1.832	136.0
86	1.924	136.0
87	2.020	136.0
88	2.121	136.0
89	2.227	136.0
90	2.338	136.0
91	2.455	136.0
92	2.578	136.0
93	2.707	136.0
94	2.842	136.0
95	2.984	136.0
96	3.133	136.0
97	3.290	136.0
98	3.454	136.0
99	3.627	136.0
100	3.808	136.0
101	3.998	136.0
102	4.198	136.0
103	4.408	136.0
104	4.628	136.0
105	4.859	136.0
107	5.000	136.0



108	5.250	135.6
109	5.512	135.1
110	5.788	134.7
111	6.077	134.3
112	6.381	133.9
113	6.700	133.5
114	7.035	133.0
115	7.387	132.6
116	7.756	132.2
117	8.144	131.8
118	8.551	131.3
119	8.979	130.9
120	9.428	130.5
121	9.899	130.1
122	10.394	129.6
123	10.914	129.2
124	11.460	128.8
125	12.033	128.4
126	12.635	127.9
127	13.267	127.5
128	13.930	127.1
129	14.626	126.7
130	15.357	126.3
131	16.125	125.8
132	16.931	125.4
133	17.778	125.0
134	18.667	124.6
135	19.600	124.2
136	20.580	123.7
137	21.609	123.3
138	22.689	122.9
139	23.823	122.4
140	25.014	122.0
141	26.265	121.6
142	27.578	121.2
143	28.957	120.8
144	30.405	120.3
145	31.925	119.9



146	33.521	119.5
147	35.197	119.1
148	36.957	118.7
149	38.805	118.2
150	40.745	117.8
151	42.782	117.4
152	44.921	116.9
153	47.167	116.5
154	49.525	116.1
155	52.001	115.7
156	54.601	115.3
157	57.331	114.8
158	60.198	114.4
159	63.208	114.0
160	66.368	113.6
161	69.686	113.1
162	73.170	112.7
163	76.828	112.3
164	80.669	111.9
165	84.702	111.4
166	88.937	111.0
167	93.384	110.6
168	98.053	110.2
169	102.956	109.8
170	108.104	109.3
171	113.509	108.9
172	119.184	108.5
173	125.143	108.1
174	131.400	107.6
175	137.970	107.2
176	144.868	106.8
177	150.000	106.5



L2to L3 test data:

Test center CCS

TEST REPORT

Report No. : 90626003

Standard MIL STD-461E/F CS101

Test object 20.1 Multimedia LCD Monitor
WMMRM920-PIP

Customer iTech Company LLC

Test engineer Eric

Recorded July 6, 2009 4:28:45 pm , with ICD 3.50.11

Test equipment 1.) EM TEST AG, CWS 500E, RE9E0E9Q9A

Result file C:\EMTEST\ICD350\RESULT\11.prj

Description Class : A

Result Test passed

Testfile

Name curve 1 136dbuv ac 5%.nrm

Path c:\emtest\icd350\standard\automotive\international\iso\cns
9589\mil-std-461f\complate\cs101\curve 1 136dbuv ac 5%.nrm

Modification date 2009/7/2 11:48:52

Climatic condition

Temperature 23

Humidity 54

Pressure 1020

Test Values

no.	title	F1 [kHz]	L1 [dBuV]	F2 [kHz]	L2 [dBuV]	F-step [kHz]	td [s]	tp [s]	Modulation
1.	Curve #1	0.030	136.0	5.000	136.0	5.0 %	3.0 s	0.0 s	CW
2.		5.000	136.0	150.000	106.5	5.0 %	3.0 s	0.0 s	CW



Diagrams

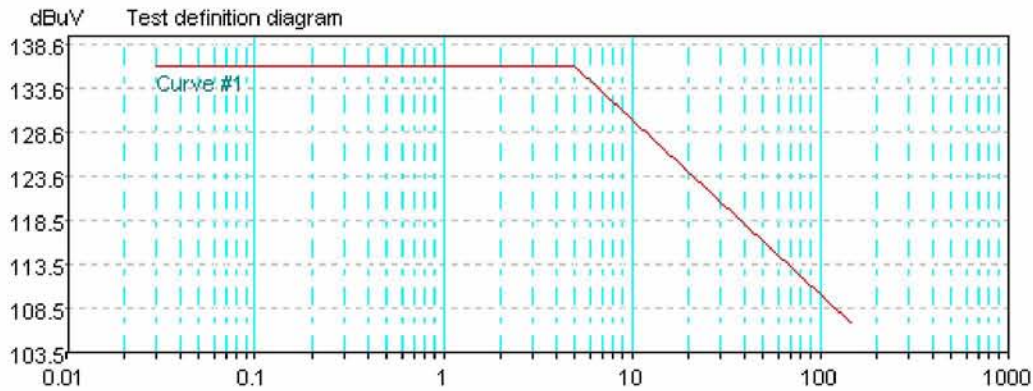

Test summary

no.	Calibration file	Tp. count	Ev. count	passed
1.	Trafo2-1 Curve #1 0_03 - 150_0 kHz, 5_0 %.CAL	176/177	1	no

Coupling device: 1

Model Trafo2-1
Sno
Note 60VAC, 50ADC max
Frequency range 0.010 .. 250.000 kHz
Coupling port DC-Port
description

Diagrams

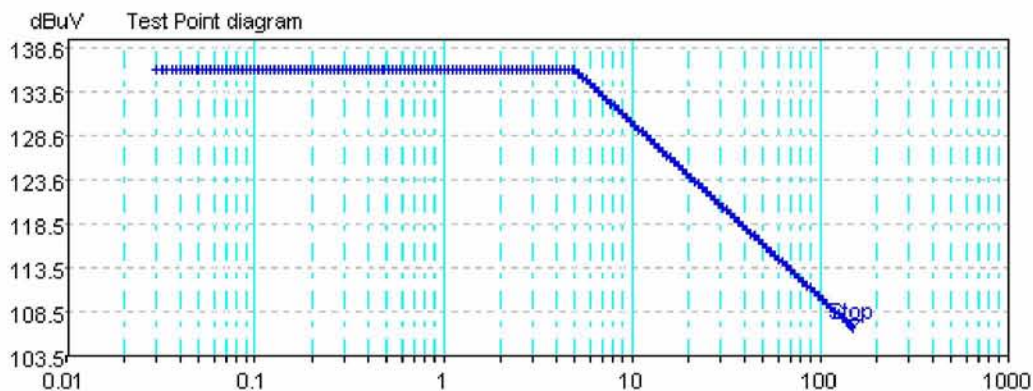



Table of events : 1

no.	Events	Frequency [kHz]	Level [dBuV]	Comment
1	Stop	150.000	106.5	

Table of Test points : 176

no.	Frequency [kHz]	Level [dBuV]
1	0.030	136.0
2	0.032	136.0
3	0.034	136.0
4	0.036	136.0
5	0.038	136.0
6	0.040	136.0
7	0.042	136.0
8	0.044	136.0
9	0.046	136.0
10	0.048	136.0
11	0.050	136.0
12	0.052	136.0
13	0.055	136.0
14	0.058	136.0
15	0.061	136.0
16	0.064	136.0
17	0.067	136.0
18	0.070	136.0
19	0.074	136.0
20	0.078	136.0
21	0.082	136.0
22	0.086	136.0
23	0.090	136.0
24	0.094	136.0
25	0.099	136.0
26	0.104	136.0
27	0.109	136.0
28	0.114	136.0
29	0.120	136.0
30	0.126	136.0



31	0.132	136.0
32	0.139	136.0
33	0.146	136.0
34	0.153	136.0
35	0.161	136.0
36	0.169	136.0
37	0.177	136.0
38	0.186	136.0
39	0.195	136.0
40	0.205	136.0
41	0.215	136.0
42	0.226	136.0
43	0.237	136.0
44	0.249	136.0
45	0.261	136.0
46	0.274	136.0
47	0.288	136.0
48	0.302	136.0
49	0.317	136.0
50	0.333	136.0
51	0.350	136.0
52	0.368	136.0
53	0.386	136.0
54	0.405	136.0
55	0.425	136.0
56	0.446	136.0
57	0.468	136.0
58	0.491	136.0
59	0.516	136.0
60	0.542	136.0
61	0.569	136.0
62	0.597	136.0
63	0.627	136.0
64	0.658	136.0
65	0.691	136.0
66	0.726	136.0
67	0.762	136.0
68	0.800	136.0



69	0.840	136.0
70	0.882	136.0
71	0.926	136.0
72	0.972	136.0
73	1.021	136.0
74	1.072	136.0
75	1.126	136.0
76	1.182	136.0
77	1.241	136.0
78	1.303	136.0
79	1.368	136.0
80	1.436	136.0
81	1.508	136.0
82	1.583	136.0
83	1.662	136.0
84	1.745	136.0
85	1.832	136.0
86	1.924	136.0
87	2.020	136.0
88	2.121	136.0
89	2.227	136.0
90	2.338	136.0
91	2.455	136.0
92	2.578	136.0
93	2.707	136.0
94	2.842	136.0
95	2.984	136.0
96	3.133	136.0
97	3.290	136.0
98	3.454	136.0
99	3.627	136.0
100	3.808	136.0
101	3.998	136.0
102	4.198	136.0
103	4.408	136.0
104	4.628	136.0
105	4.859	136.0
107	5.000	136.0



108	5.250	135.6
109	5.512	135.1
110	5.788	134.7
111	6.077	134.3
112	6.381	133.9
113	6.700	133.5
114	7.035	133.0
115	7.387	132.6
116	7.756	132.2
117	8.144	131.8
118	8.551	131.3
119	8.979	130.9
120	9.428	130.5
121	9.899	130.1
122	10.394	129.6
123	10.914	129.2
124	11.460	128.8
125	12.033	128.4
126	12.635	127.9
127	13.267	127.5
128	13.930	127.1
129	14.626	126.7
130	15.357	126.3
131	16.125	125.8
132	16.931	125.4
133	17.778	125.0
134	18.667	124.6
135	19.600	124.2
136	20.580	123.7
137	21.609	123.3
138	22.689	122.9
139	23.823	122.4
140	25.014	122.0
141	26.265	121.6
142	27.578	121.2
143	28.957	120.8
144	30.405	120.3
145	31.925	119.9



146	33.521	119.5
147	35.197	119.1
148	36.957	118.7
149	38.805	118.2
150	40.745	117.8
151	42.782	117.4
152	44.921	116.9
153	47.167	116.5
154	49.525	116.1
155	52.001	115.7
156	54.601	115.3
157	57.331	114.8
158	60.198	114.4
159	63.208	114.0
160	66.368	113.6
161	69.686	113.1
162	73.170	112.7
163	76.828	112.3
164	80.669	111.9
165	84.702	111.4
166	88.937	111.0
167	93.384	110.6
168	98.053	110.2
169	102.956	109.8
170	108.104	109.3
171	113.509	108.9
172	119.184	108.5
173	125.143	108.1
174	131.400	107.6
175	137.970	107.2
176	144.868	106.8
177	150.000	106.5



L3to L2 test data:

Test center CCS

TEST REPORT

Report No. : 90626003

Standard MIL STD-461E/F CS101

Test object 20.1 Multimedia LCD Monitor
 WMRM920-PIP

Customer iTech Company LLC

Test engineer Eric

Recorded July 6, 2009 5:38:46 pm , with ICD 3.50.11

Test equipment 1.) EM TEST AG, CWS 500E, RE9E0E9Q9A

Result file C:\EMTEST\ICD350\RESULT\11.prj

Description Class : A

Result Test passed

Testfile

Name curve 1 136dbuv ac 5%.nrm

Path c:\emtest\icd350\standard\automotive\international\iso\cns
 9589\mil-std-461f\complate\cs101\curve 1 136dbuv ac 5%.nrm

Modification date 2009/7/2 11:48:52

Climatic condition

Temperature 23

Humidity 54

Pressure 1020

Test Values

no.	title	F1 [kHz]	L1 [dBuV]	F2 [kHz]	L2 [dBuV]	F-step [kHz]	td [s]	tp [s]	Modulation
1.	Curve #1	0.030	136.0	5.000	136.0	5.0 %	3.0 s	0.0 s	CW
2.		5.000	136.0	150.000	106.5	5.0 %	3.0 s	0.0 s	CW



Diagrams

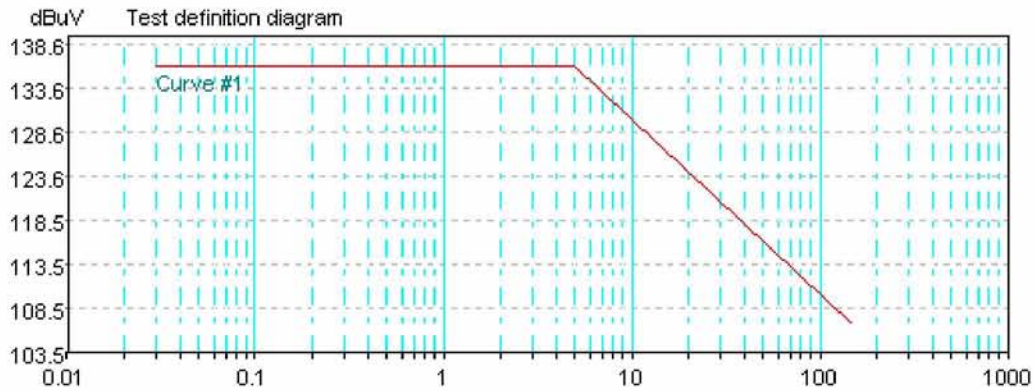

Test summary

no.	Calibration file	Tp. count	Ev. count	passed
1.	Trafo2-1 Curve #1 0_03 - 150_0 kHz, 5_0 %.CAL	176/177	1	no

Coupling device: 1

Model Trafo2-1
Sno
Note 60VAC, 50ADC max
Frequency range 0.010 .. 250.000 kHz
Coupling port DC-Port
description

Diagrams

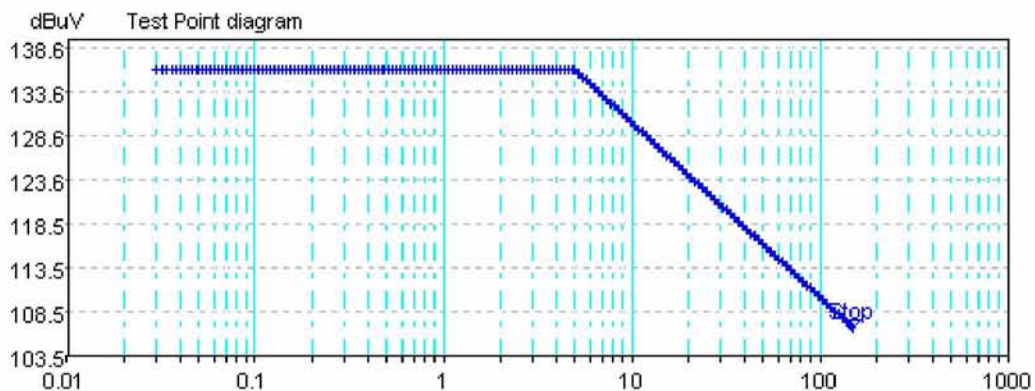



Table of events : 1

no.	Events	Frequency [kHz]	Level [dBuV]	Comment
1	Stop	150.000	106.5	

Table of Test points : 176

no.	Frequency [kHz]	Level [dBuV]
1	0.030	136.0
2	0.032	136.0
3	0.034	136.0
4	0.036	136.0
5	0.038	136.0
6	0.040	136.0
7	0.042	136.0
8	0.044	136.0
9	0.046	136.0
10	0.048	136.0
11	0.050	136.0
12	0.052	136.0
13	0.055	136.0
14	0.058	136.0
15	0.061	136.0
16	0.064	136.0
17	0.067	136.0
18	0.070	136.0
19	0.074	136.0
20	0.078	136.0
21	0.082	136.0
22	0.086	136.0
23	0.090	136.0
24	0.094	136.0
25	0.099	136.0
26	0.104	136.0
27	0.109	136.0
28	0.114	136.0
29	0.120	136.0
30	0.126	136.0



31	0.132	136.0
32	0.139	136.0
33	0.146	136.0
34	0.153	136.0
35	0.161	136.0
36	0.169	136.0
37	0.177	136.0
38	0.186	136.0
39	0.195	136.0
40	0.205	136.0
41	0.215	136.0
42	0.226	136.0
43	0.237	136.0
44	0.249	136.0
45	0.261	136.0
46	0.274	136.0
47	0.288	136.0
48	0.302	136.0
49	0.317	136.0
50	0.333	136.0
51	0.350	136.0
52	0.368	136.0
53	0.386	136.0
54	0.405	136.0
55	0.425	136.0
56	0.446	136.0
57	0.468	136.0
58	0.491	136.0
59	0.516	136.0
60	0.542	136.0
61	0.569	136.0
62	0.597	136.0
63	0.627	136.0
64	0.658	136.0
65	0.691	136.0
66	0.726	136.0
67	0.762	136.0
68	0.800	136.0



69	0.840	136.0
70	0.882	136.0
71	0.926	136.0
72	0.972	136.0
73	1.021	136.0
74	1.072	136.0
75	1.126	136.0
76	1.182	136.0
77	1.241	136.0
78	1.303	136.0
79	1.368	136.0
80	1.436	136.0
81	1.508	136.0
82	1.583	136.0
83	1.662	136.0
84	1.745	136.0
85	1.832	136.0
86	1.924	136.0
87	2.020	136.0
88	2.121	136.0
89	2.227	136.0
90	2.338	136.0
91	2.455	136.0
92	2.578	136.0
93	2.707	136.0
94	2.842	136.0
95	2.984	136.0
96	3.133	136.0
97	3.290	136.0
98	3.454	136.0
99	3.627	136.0
100	3.808	136.0
101	3.998	136.0
102	4.198	136.0
103	4.408	136.0
104	4.628	136.0
105	4.859	136.0
107	5.000	136.0



108	5.250	135.6
109	5.512	135.1
110	5.788	134.7
111	6.077	134.3
112	6.381	133.9
113	6.700	133.5
114	7.035	133.0
115	7.387	132.6
116	7.756	132.2
117	8.144	131.8
118	8.551	131.3
119	8.979	130.9
120	9.428	130.5
121	9.899	130.1
122	10.394	129.6
123	10.914	129.2
124	11.460	128.8
125	12.033	128.4
126	12.635	127.9
127	13.267	127.5
128	13.930	127.1
129	14.626	126.7
130	15.357	126.3
131	16.125	125.8
132	16.931	125.4
133	17.778	125.0
134	18.667	124.6
135	19.600	124.2
136	20.580	123.7
137	21.609	123.3
138	22.689	122.9
139	23.823	122.4
140	25.014	122.0
141	26.265	121.6
142	27.578	121.2
143	28.957	120.8
144	30.405	120.3
145	31.925	119.9



146	33.521	119.5
147	35.197	119.1
148	36.957	118.7
149	38.805	118.2
150	40.745	117.8
151	42.782	117.4
152	44.921	116.9
153	47.167	116.5
154	49.525	116.1
155	52.001	115.7
156	54.601	115.3
157	57.331	114.8
158	60.198	114.4
159	63.208	114.0
160	66.368	113.6
161	69.686	113.1
162	73.170	112.7
163	76.828	112.3
164	80.669	111.9
165	84.702	111.4
166	88.937	111.0
167	93.384	110.6
168	98.053	110.2
169	102.956	109.8
170	108.104	109.3
171	113.509	108.9
172	119.184	108.5
173	125.143	108.1
174	131.400	107.6
175	137.970	107.2
176	144.868	106.8
177	150.000	106.5

8. APPENDIX I PHOTOGRAPHS OF TEST SETUP

CS101, Conducted susceptibility, power leads, 30 Hz to 150 kHz

