



MIL STD 461 E/F

TEST REPORT

For

Model Number:

WMRM920-PIP

Trade Name: iTech

Issued to

**iTech Company LLC
41758 Christy Street,
Fremont CA 94538 USA**

Issued by

**Compliance Certification Services Inc.
No. 11, Wugong 6th Rd., Wugu Industrial Park
Taipei Hsien 248, Taiwan
<http://www.ccsemc.com.tw>
service@tw.ccsemc.com**

Note: This report shall not be reproduced except in full, without the written approval of Compliance Certification Services Inc. This document may be altered or revised by Compliance Certification Services Inc. personnel only, and shall be noted in the revision section of the document.



TABLE OF CONTENTS

1. TEST RESULT CERTIFICATION	3
2. EUT DESCRIPTION.....	4
3. TEST METHODOLOGY.....	5
4. INSTRUMENT AND CALIBRATION.....	5
4.1 MEASURING INSTRUMENT CALIBRATION	5
4.2 MEASUREMENT EQUIPMENT USED	5
5. FACILITIES AND ACCREDITATIONS.....	6
5.1 FACILITIES	6
6. SETUP OF EQUIPMENT UNDER TEST.....	7
6.1 SETUP CONFIGURATION OF EUT	7
6.2 PHOTOGRAPHS OF EUT	7
6.3 SUPPORT EQUIPMENT	7
6.4 TEST SETUP	7
7. MIL STD 461E/F REQUIREMENTS	8
7.1 CE102, CONDUCTED EMISSIONS, POWER LEADS, 10 KHZ TO 10MHZ.....	8
8. APPENDIX I PHOTOGRAPHS OF TEST SETUP	14



1. TEST RESULT CERTIFICATION

Applicant: iTech Company LLC
 41758 Christy Street,
 Fremont CA 94538 USA

Equipment Under Test: 20.1 Multimedia LCD Monitor

Trade Name: iTech

Model Number: WMRM920-PIP

Date of Test: July 6, 2009

APPLICABLE STANDARDS	
STANDARD	TEST RESULT
MIL STD 461E/F	No non-compliance noted
Applicable Standard	Test Result
MIL STD 461E/F	
CE102: Conducted emissions, power leads, 10 kHz to 10 MHz.	No non-compliance noted
Deviation from Applicable Standard	
N/A	

The above equipment was tested by Compliance Certification Services Inc. for compliance with the requirements set forth in MIL STD 461E/F. The results of testing in this report apply only to the product/system, which was tested. Other similar equipment will not necessarily produce the same results due to production tolerance and measurement uncertainties.

Approved by:

Reviewed by:

James Lee
 Section Manager
 Compliance Certification Services Inc.

Bruce Chen
 Senior Engineer
 Compliance Certification Services Inc.



2. EUT DESCRIPTION

Product	20.1 Multimedia LCD Monitor
Trade Name	iTech
Model Number	WMRM920-PIP
Model Discrepancy	
EUT Power Rating	MB: iTech/ R2A Panel LCD: 20.1 AUO / M201UN02-V6 Power Board: Wearnes/ WDS080121 RS232 Port: Link PC /Touch

Remark: for more details, please refer to the User's manual of the EUT.



3. TEST METHODOLOGY

All tests were performed in accordance with the procedure documented in MIL STD 461E/F.

4. INSTRUMENT AND CALIBRATION

4.1 MEASURING INSTRUMENT CALIBRATION

The measuring equipment, which was utilized in performing the tests documented herein, has been calibrated in accordance with the manufacturer’s recommendations for utilizing calibration equipment, which is traceable to recognized national standards.

4.2 MEASUREMENT EQUIPMENT USED

Equipment Used for Emissions Measurement

CISPR 25 Radiation Emission (CE102)				
Name of Equipment	Manufacturer	Model	Serial Number	Calibration Due
EMI Test Receiver	R&S	ESCI	100312	04/16/2010
Spectrum Analyzer	Agilent	E4446A	MY43360131	02/25/2010
Pre-Amplifier	Mini-Circuits	ZKL-500	120406	07/01/2010
Coaxial Cable	Huber Suhner	SUCOFLEX	001	07/01/2010
Coaxial Cable	Huber Suhne	SUCOFLEX	002	07/01/2010
LISN	R&S	AT/A38	8448773	10/27/2009
Site NSA	CCS	N/A	N/A	01/02/2010
Software	Turbo C++			



5. FACILITIES AND ACCREDITATIONS

5.1 FACILITIES

All measurement facilities used to collect the measurement data are located at

No.199, Chunghsen Road, Hsintien City, Taipei Hsien, Taiwan, R.O.C.

Tel: 886-2-2217-0894 / Fax: 886-2-2217-1029

No.11, Wugong 6th Rd., Wugu Industrial Park, Taipei Hsien 248, Taiwan

Tel: 886-2-2299-9720 / Fax: 886-2-2299-9721

No.81-1, Lane 210, Bade 2nd Rd., Luchu Hsiang, Taoyuan Hsien 338, Taiwan

Tel: 886-3-324-0332 / Fax: 886-3-324-5235

The sites are constructed in conformance with the requirements of ANSI C63.7, ANSI C63.4 and CISPR Publication 22.



6. SETUP OF EQUIPMENT UNDER TEST

6.1 SETUP CONFIGURATION OF EUT

See test photographs attached in Appendix 1 for the actual connections between EUT and support equipment.

6.2 PHOTOGRAPHS OF EUT

See test photographs attached in Appendix 2 for the EUT's internal structure.

6.3 SUPPORT EQUIPMENT

No.	Device Type	Brand	Model	Series No.	FCC ID	Data Cable	Power Cord
1	Notebook PC	DELL	PP19L	GH645 A03	E2KWM3945ABG	N/A	N/A

Remarks:

- 1. All the above equipment/cables were placed in worse case positions to maximize emission signals during emission test.*
- 2. Grounding was established in accordance with the manufacturer's requirements and conditions for the intended use.*

6.4 TEST SETUP

The equipment under test was configured in normal operation continuously. EUT tends to maximize its emission characteristics in a typical application for conducted emission measurement. The EUT was active during the conducted emission measurements.

7. MIL STD 461E/F REQUIREMENTS

7.1 CE102, conducted emissions, power leads, 10 kHz to 10MHz

LIMIT

Conducted emissions on power leads shall not exceed the applicable values shown on Figure CE102-1.

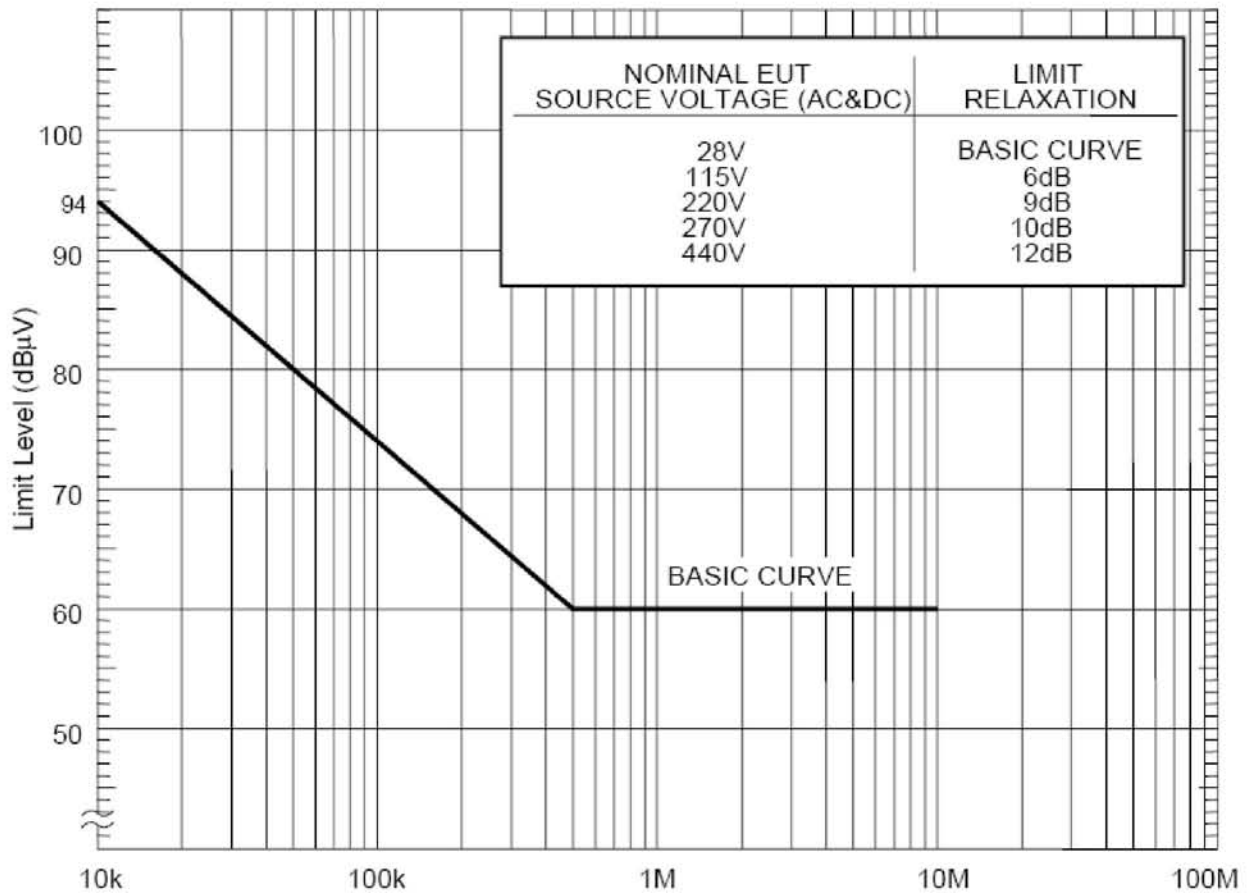
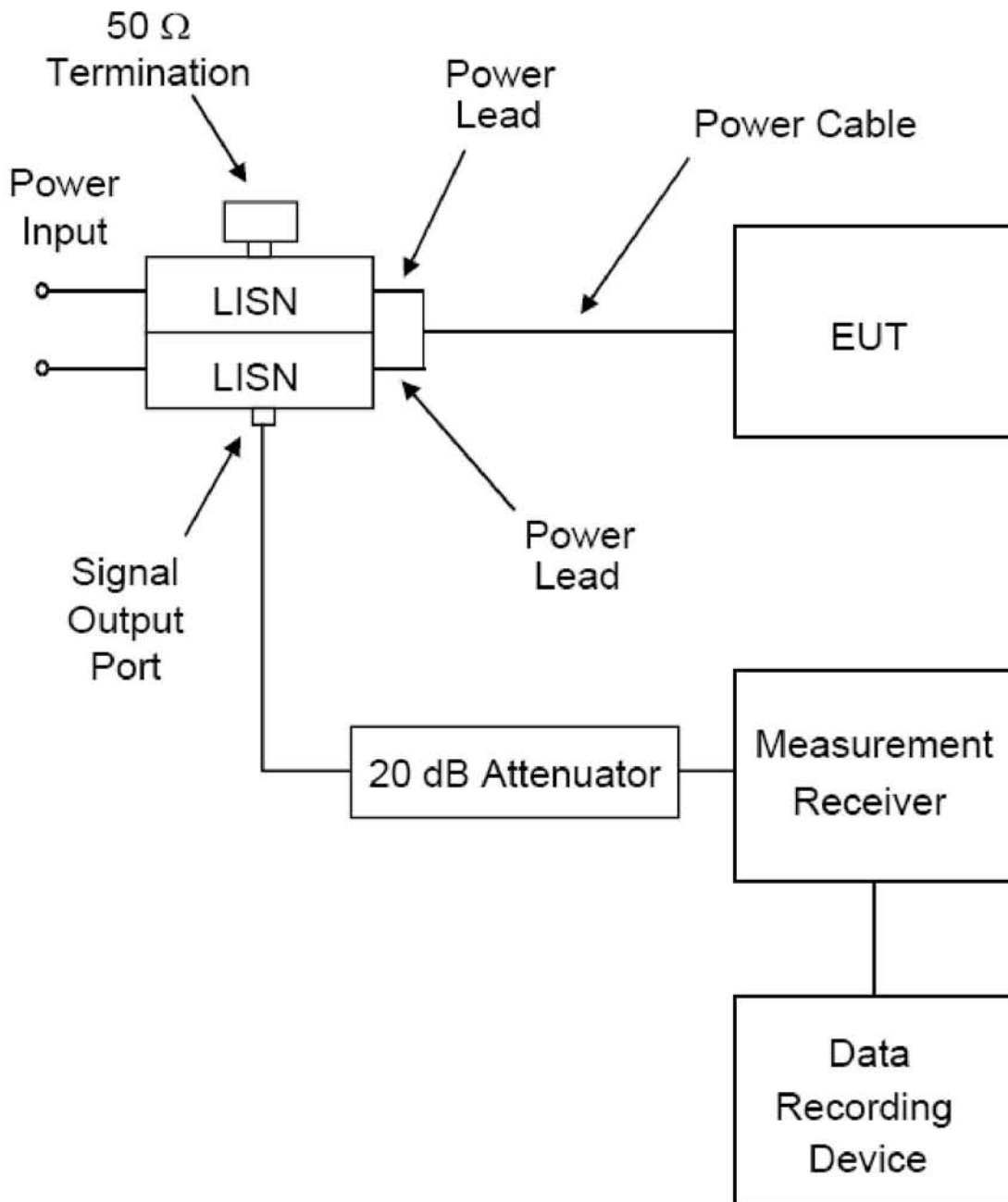

FIGURE CE102-1. CE102 limit (EUT power leads, AC and DC) for all applications.

TEST CONFIGURATION



TEST PROCEDURE

The magnetic emission of EUT representative of its type shall be tested by the method(s) according to MIL STD 461E/F.



TEST RESULTS

No non-compliance noted

Test Data

0.01MHz-0.15MHz-L1

Job No.:	90626003	Polarization:	L1
Standard:	MIL-STD-461E/F CE102 (AC&DC)-115V	Power Source:	AC 120V/60Hz
Test item:	Conduction Test	Date:	2009/7/6
Temp.(°C)/Hum.(%):	22(°C)/51%	Time:	上午 10:38:10
Company:	iTech Company LLC	Engineer	Chris
		Signature:	
Trade Name:	iTech	Distance:	
Model:	WMRM920-PIP	RBW: 1kHz	VBW: 1kHz
Description:	VGA Mode		

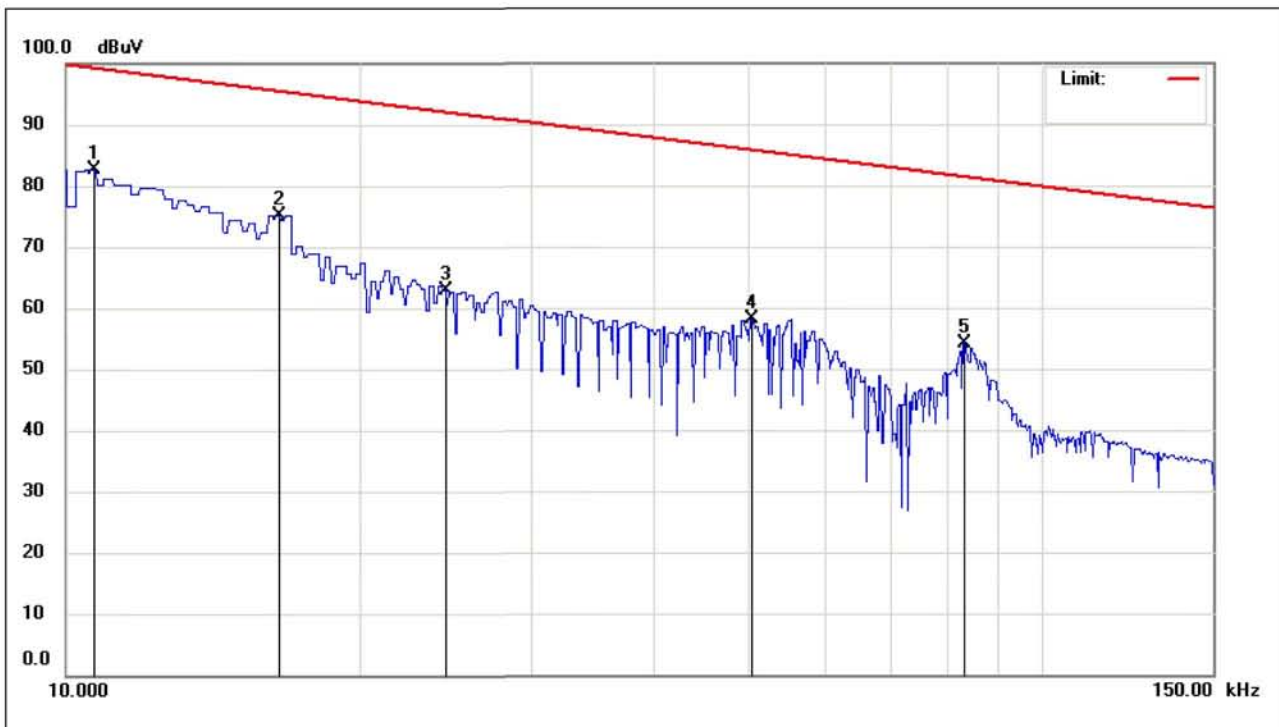

No.	Frequency (KHz)	Reading (dBuV)	Factor (dB)	Result (dBuV)	Limit (dBuV)	Margin (dB)	Detector	P/F	Remark
1	10.7000	82.12	0.60	82.72	99.41	-16.69	peak	P	
2	16.5330	74.65	0.56	75.21	95.63	-20.42	peak	P	
3	24.4670	62.46	0.52	62.98	92.22	-29.24	peak	P	
4	50.3670	57.86	0.38	58.24	85.95	-27.71	peak	P	
5	83.2670	54.06	0.19	54.25	81.58	-27.33	peak	P	



0.15MHz-10MHz-L1

Job No.:	90626003	Polarization:	L1
Standard:	MIL-STD-461E/F CE102 (AC&DC)-115V	Power Source:	AC 120V/60Hz
Test item:	Conduction Test	Date:	2009/7/6
Temp.(°C)/Hum.(%):	22°C/51%	Time:	上午 10:46:19
Company:	iTech Company LLC	Engineer	Chris
		Signature:	
Trade Name:	iTech	Distance:	
Model:	WMRM920-PIP	RBW: 10kHz	VBW: 10kHz
Description:	VGA Mode		

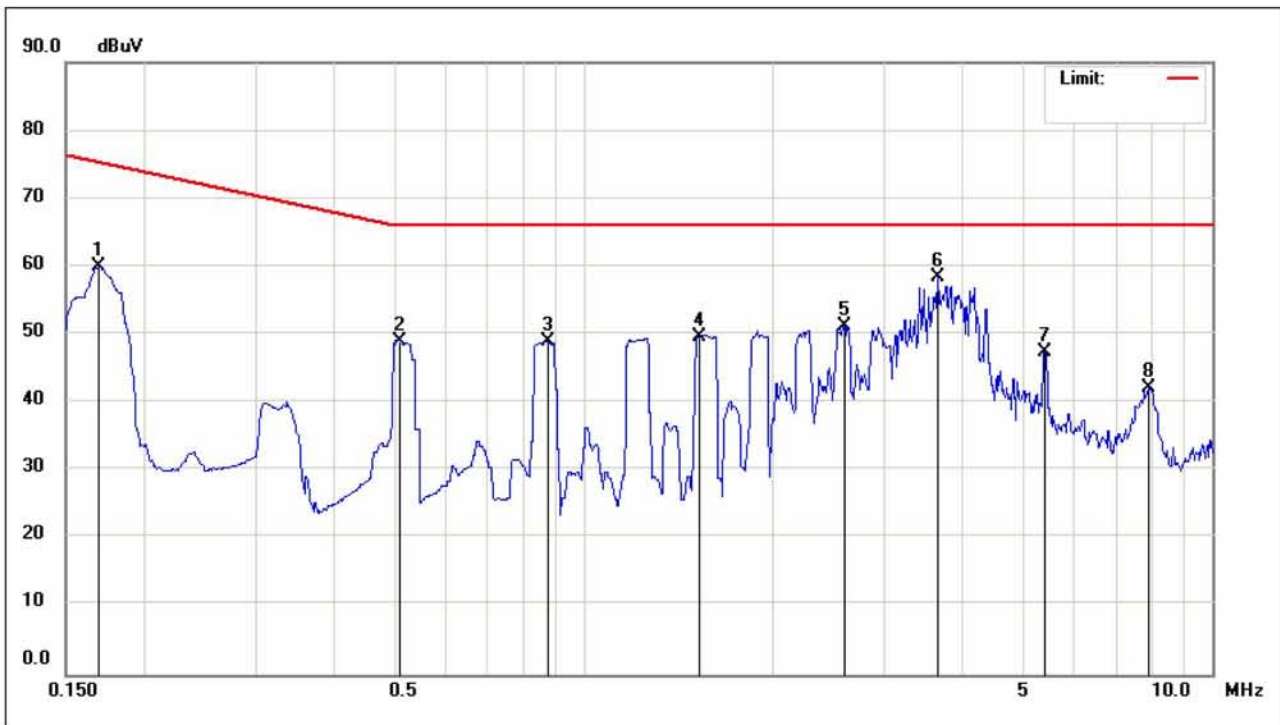

No.	Frequency (MHz)	Reading (dBuV)	Factor (dB)	Result (dBuV)	Limit (dBuV)	Margin (dB)	Detector	P/F	Remark
1	0.1692	59.90	0.10	60.00	75.42	-15.42	peak	P	
2	0.5075	48.95	0.10	49.05	66.00	-16.95	peak	P	
3	0.8750	48.73	0.10	48.83	66.00	-17.17	peak	P	
4	1.5200	49.50	0.10	49.60	66.00	-16.40	peak	P	
5	2.5925	50.97	0.13	51.10	66.00	-14.90	peak	P	
6	3.6500	58.29	0.18	58.47	66.00	-7.53	peak	P	
7	5.4000	47.00	0.29	47.29	66.00	-18.71	peak	P	



0.01MHz-0.15MHz-L2

Job No.:	90626003	Polarization:	L2
Standard:	MIL-STD-461E/F CE102 (AC&DC)-115V	Power Source:	AC 120V/60Hz
Test item:	Conduction Test	Date:	2009/7/6
Temp.(°C)/Hum.(%):	22°C/51%	Time:	上午 11:01:10
Company:	iTech Company LLC	Engineer:	Chris
		Signature:	
Trade Name:	iTech	Distance:	
Model:	WMRM920-PIP	RBW: 1kHz	VBW: 1kHz
Description:	VGA Mode		

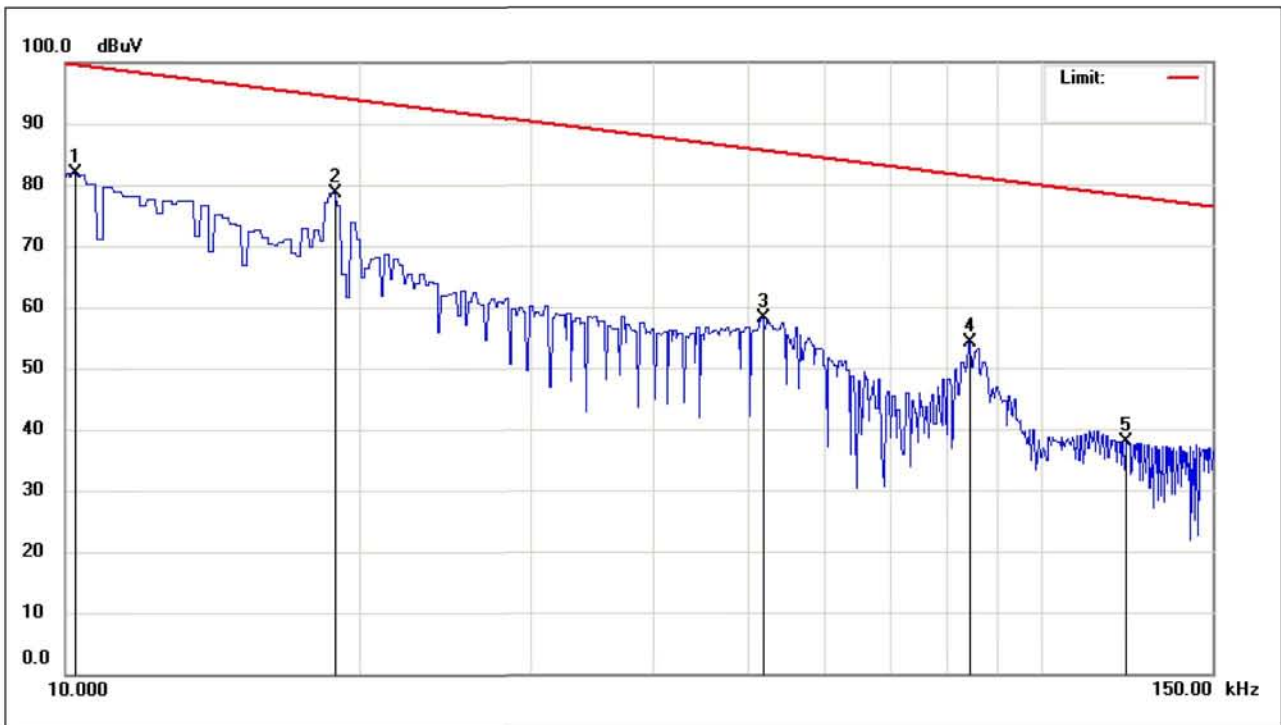

No.	Frequency (KHz)	Reading (dBuV)	Factor (dB)	Result (dBuV)	Limit (dBuV)	Margin (dB)	Detector	P/F	Remark
1	10.2330	81.22	0.60	81.82	99.80	-17.98	peak	P	
2	18.8670	77.98	0.55	78.53	94.48	-15.95	peak	P	
3	51.7670	57.73	0.37	58.10	85.71	-27.61	peak	P	
4	84.4330	54.03	0.19	54.22	81.46	-27.24	peak	P	
5	122.2330	37.87	0.10	37.97	78.24	-40.27	peak	P	



0.15MHz-10MHz-L2

Job No.:	90626003	Polarization:	L2
Standard:	MIL-STD-461E/F CE102 (AC&DC)-115V	Power Source:	AC 120V/60Hz
Test item:	Conduction Test	Date:	2009/7/6
Temp.(°C)/Hum.(%):	22°C/51%	Time:	上午 10:55:11
Company:	iTech Company LLC	Engineer:	Chris
		Signature:	
Trade Name:	iTech	Distance:	
Model:	WMRM920-PIP	RBW: 10kHz	VBW: 10kHz
Description:	VGA Mode		

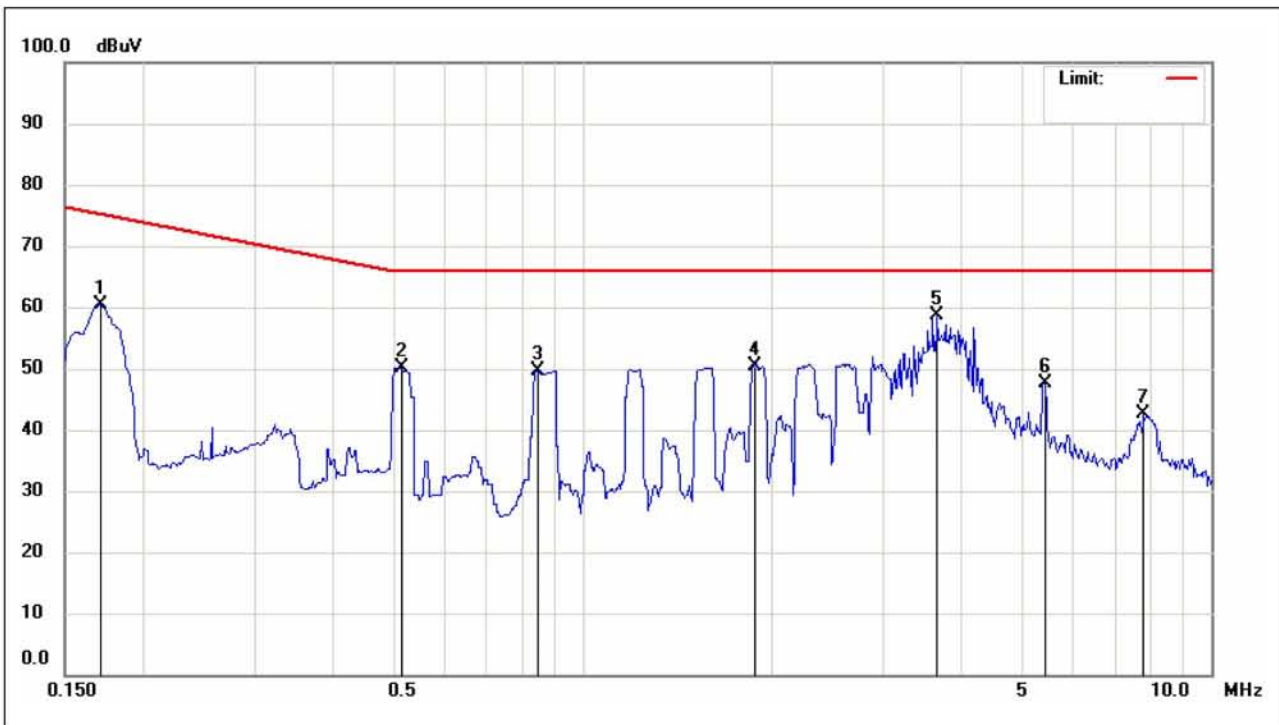

No.	Frequency (MHz)	Reading (dBuV)	Factor (dB)	Result (dBuV)	Limit (dBuV)	Margin (dB)	Detector	P/F	Remark
1	0.1704	60.16	0.10	60.26	75.36	-15.10	peak	P	
2	0.5150	49.93	0.10	50.03	66.00	-15.97	peak	P	
3	0.8450	49.57	0.10	49.67	66.00	-16.33	peak	P	
4	1.8725	50.24	0.12	50.36	66.00	-15.64	peak	P	
5	3.6575	58.49	0.13	58.62	66.00	-7.38	peak	P	
6	5.4167	47.39	0.23	47.62	66.00	-18.38	peak	P	
7	7.8000	42.29	0.39	42.68	66.00	-23.32	peak	P	

8. APPENDIX I PHOTOGRAPHS OF TEST SETUP

CE102, conducted emissions, power leads, 10 kHz to 10 MHz.

