

2U Triple 3x 17.3" 1920 x 1080 1000nits High Brightness short depth 22" design, Triple Rackmount Keyboard LCD Monitor Console Drawer 104-key keyboard with touchpad Fits 24" ~ 36" rack via adjustable mounting brackets +VGA + HDMI 2.0 w/ speaker



Model: NVP3DW17HBe-HDMI

BENEFITS

- 3 x 17" FHD display in 2U 22" short depth design
- 1920 x 1080 native resolution / 16.7M colors (8-bit)
- Sunlight readable brightness 1000 cd/m²
- VGA + HDMI 1.4 video input (per display)
- Built-in dual stereo speaker (per display)
- 104-key keyboard with touchpad
- Built-in solid bearing slide rails
- Rugged construction for mobility & durability
- Fits 24" ~ 36" rack via adjustable mounting brackets
- 2-year standard warranty (upgradable up to 5 years)

SPECIFICATIONS

LCD Panel	
Panel size (diagonal)	17.3"
Native resolution	1920 x 1080
Brightness (cd/m ²)	1000
Contrast ratio (typ.)	600 : 1
Colors	16.7 M, 8-bit
Viewing angle (L/R/U/D)	80/80/60/80
Response time (ms)	5.5
Dot pitch (mm)	0.1989
Display area (mm)	381.888H x 214.812V
Surface treatment	Anti-glare, Hard-coating
Surface hardness	3H
Backlight type	LED
MTBF (hrs)	50,000

Video	
Video input	VGA + HDMI 1.4 / HDCP 1.4
VGA console 6ft cable : NB-6A	Drawer end : DB-15 + USB type A x 2 Server end : DB-15 + USB type A x 2

Power		
Input	Auto-sensing 100 to 240VAC, 50 / 60Hz	
Consumption (per panel)	Screen on	Max. 39W
	Power saving	Max. 2W
	Power button off	Max. 1W

Compliance	
EMC	FCC & CE
Safety	CE / LVD & UKCA
Environment	REACH & RoHS3 / WEEE

Physical		
Product (W x D x H)	mm inch	441.6 x 550 x 88 17.4 x 21.7 x 3.5
Packing (W x D x H)	mm inch	580 x 683 x 197 22.8 x 26.9 x 7.8
Net Weight		25.7 kg / 56.5 lb
Gross Weight		31.1 kg / 68.4 lb
Chassis color		Dark
Chassis materials		Steel

Environment	
Operating temp.	0 to 55°C degree
Storage temp.	-20 to 60°C degree
Operating humidity	20~90%, non-condensing
Storage humidity	5 ~90%, non-condensing
Operating altitude	16,000 ft
Non-operating altitude	40,000 ft
Shock	10G acceleration (11ms duration)
Vibration	10~300Hz 0.5G RMS random vibration







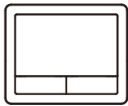
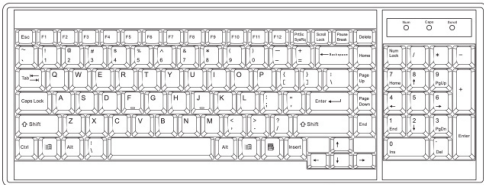

**Specifications subject to change without notice, not responsible for typographical errors.*

STANDARD KEYBOARD

e keyboard with touchpad



Supporting layouts

America						
	U.S.					
EMEA						
	U.K.	Germany	France	Russia	Spain	Italy
Asia						
	Japan	Korea				

MECHANICAL DRAWINGS

This is subject to change without Notice. Final Drawings Will be Provided for Approval after Order.

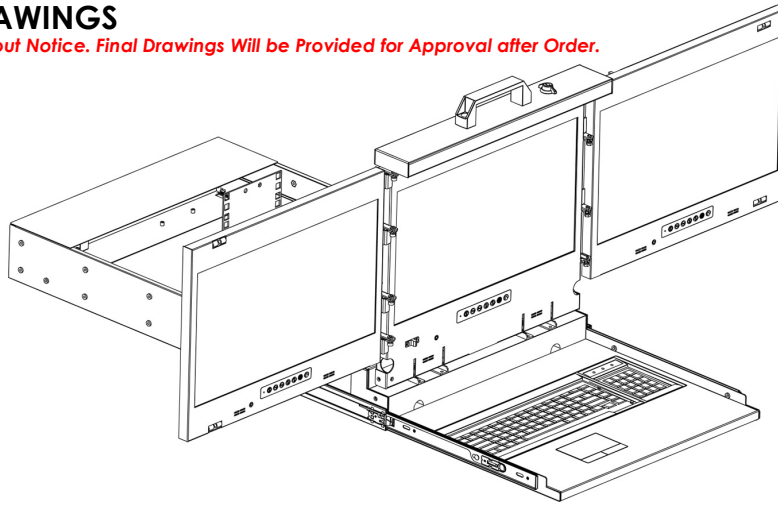

Front View

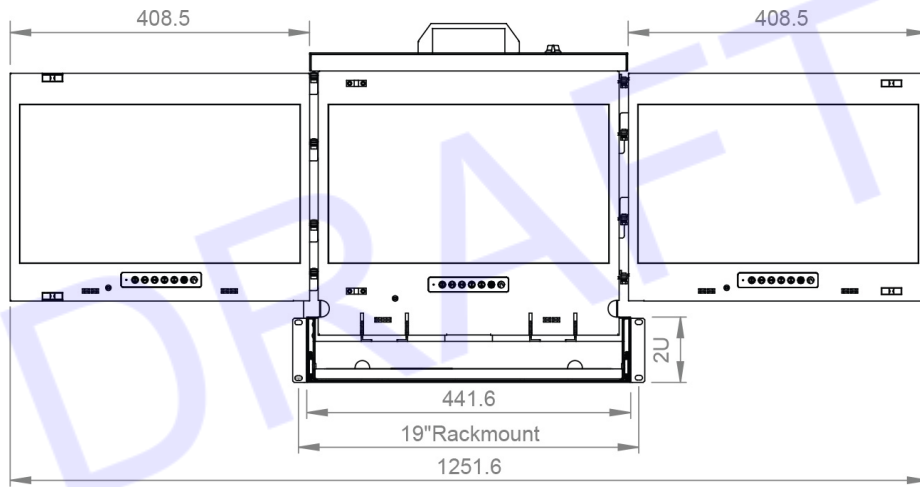

Side View

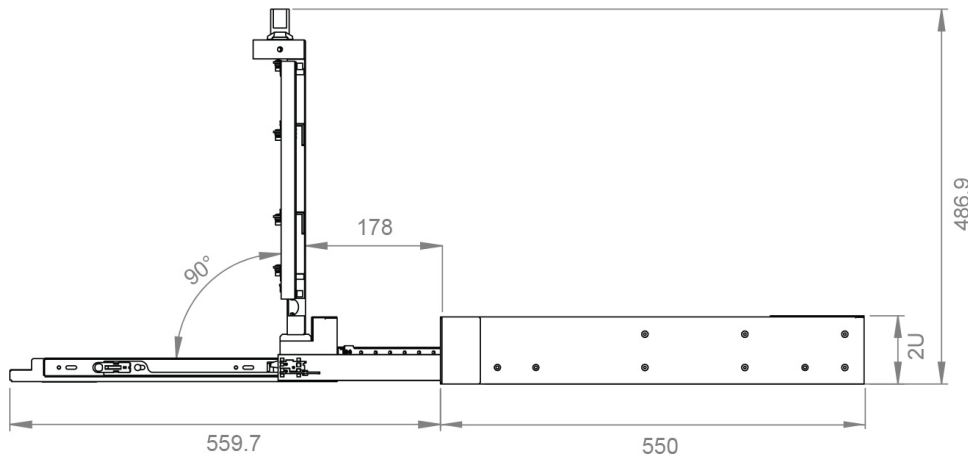

Rear View

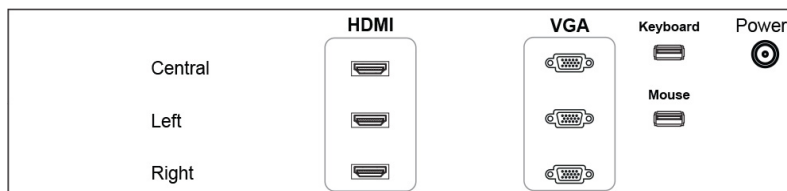

Drawing no.: NVP3DW17HBe-HDMI-08052022-V1

Modified: 08-05-2022