

2U 19" 4:3 Dual Display Console Drawer (Right Hinged Mount)  
1280x1024 Native Resolution DVI-D + VGA Video Input

+104-key keyboard with touchpad ( PS2 / USB )  
+USB K/B & MS selector for Triple Display



**Model: NVP2D19e-R-KM**

## KEY BENEFITS

- 2U 22" short depth design
- Light weight
- Rugged construction for mobility & durability
- Built-in solid bearing slide rails
- Built-in dual stereo speaker ( per display )
- DVI-D + VGA video input ( per display )
- 104-key keyboard with either touchpad or trackball ( PS2 / USB )
- Fits 24" ~ 36" rack via adjustable mounting brackets
- 2-year standard warranty ( upgradable up to 5 years )
- TAA Complaint

## OPTIONS

- DC power : 12V / 24V / 48V / 125V / 250V
- 3G / HD / SD-SDI Broadcast-grade input
- Sunlight readable LCD
- Touchscreen
- Front USB hub port for device access
- HDMI video input
- MAC or SUN Micro keyboard
- USB keyboard & mouse selector

## SPECIFICATIONS

Native resolution	1280 x 1024
Panel size (diagonal)	19"
Refresh rate (Hz)	60 / 75
Brightness (cd/m <sup>2</sup> )	250
High Brightness (cd/m <sup>2</sup> ) - Option	1000
Contrast ratio (typ.)	1000 : 1
Colors	16.7 M
Viewing angle (L/R/U/D)	85/85/80/80
Response time (ms)	5
Dot pitch (mm)	0.294
Display area (mm)	337.92H x 270.33V
Surface treatment	Anti-glare, Hard-coating
Surface hardness	3H
Backlight type	LED
MTBF (hrs)	30,000

<b>Video</b>	
Package	DVI-D + VGA
Option	HDMI 1.2 / HDCP 1.1

*\*Specifications subject to change without notice, not responsible for typographical errors.*

## RESISTIVE TOUCH SCREEN OPTION

<b>Technology</b>	5-Wire Resistive
<b>Touch Point</b>	Single
<b>Input Type</b>	Finger or Stylus
<b>Resolution</b>	2048 x 2048
<b>Response Speed</b>	15 ms
<b>Activation Force</b>	< 50 g
<b>Surface Hardness</b>	3H
<b>Light Transmission</b>	80% ± 3%
<b>Haze</b>	8% ± 3%
<b>Durability</b>	10 million touches
<b>Top Layer</b>	ITO Film
<b>Bottom Layer</b>	ITO Glass
<b>Thickness</b>	2.2 ± 0.2 mm
<b>Connector</b>	USB Type A
<b>Compatibility</b>	Windows 7 / XP / Linux / Mac

<b>Power</b>		
	Input	Auto-sensing 100 to 240VAC, 50 / 60Hz
Consumption per panel	Screen on	Max. 22W
	Power saving	Max. 2W
	Power button off	Max. 1W

<b>Physical</b>		
Product (W x D x H)	mm	441.6 x 600 x 88 22.8 x 23.6 x 7.8
Packing (W x D x H)	mm inch	581 x 753 x 216 22.9 x 29.7 x 8.5
Net Weight	Dual display	22 kg / 48.4 lb
Gross Weight	Dual display	27 kg / 59.4 lb
Chassis color		Dark
Chassis materials		Steel

<b>Compliance</b>	
EMC	FCC & CE certified
Safety	CE / LVD certified
Environment	REACH & RoHS3 / WEEE

<b>Environment</b>	
Operating temp.	0 to 55°C degree
Storage temp.	-20 to 60°C degree
Operating humidity	10~90%, non-condensing
Storage humidity	5 ~90%, non-condensing
Operating altitude	16,000 ft
Non-operating	40,000 ft
Shock	10G acceleration ( 11ms duration )
Vibration	10~300Hz 0.5G RMS random vibration

## USB KEYBOARD & MOUSE SELECTOR

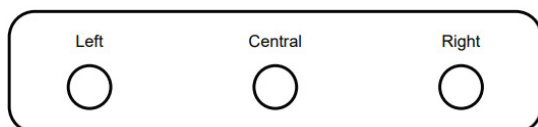

- Enables 2 or 3 computers to share keyboard & mouse.
- Easily switch to any of your connected computers with the press of a button

## STANDARD KEYBOARD

[ e ] Keyboard with Touchpad

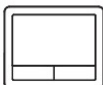
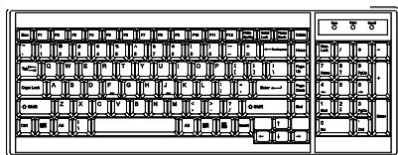

[ b ] Keyboard with Trackball

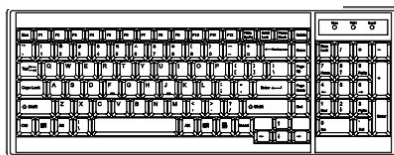

### Supporting layouts

America		U.S.
EMEA		U.K. Germany France Russia Spain Italy
Asia		Japan Korea

## KEYBOARD LAYOUT OPTIONS

**Me** Mac keyboard with touchpad



**Se** S keyboard with touchpad



**Mb** Mac keyboard with trackball

**Sb** S keyboard with trackball

# MECHANICAL DRAWINGS

This is subject to change without Notice. Final Drawings Will be Provided for Approval after Order.

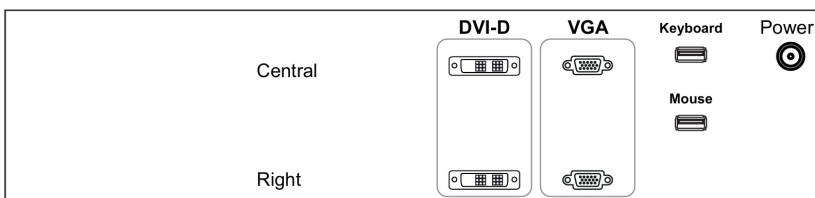
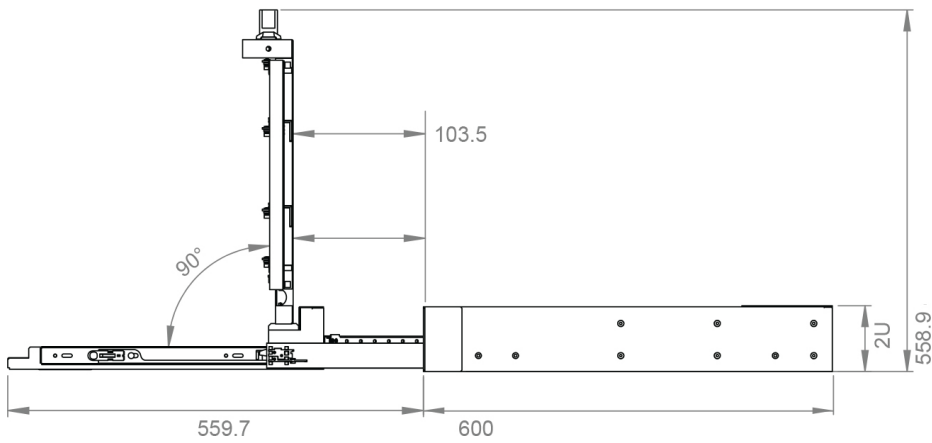
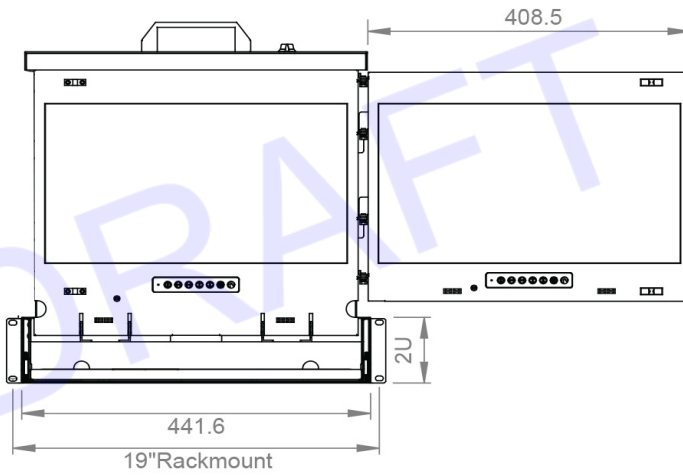
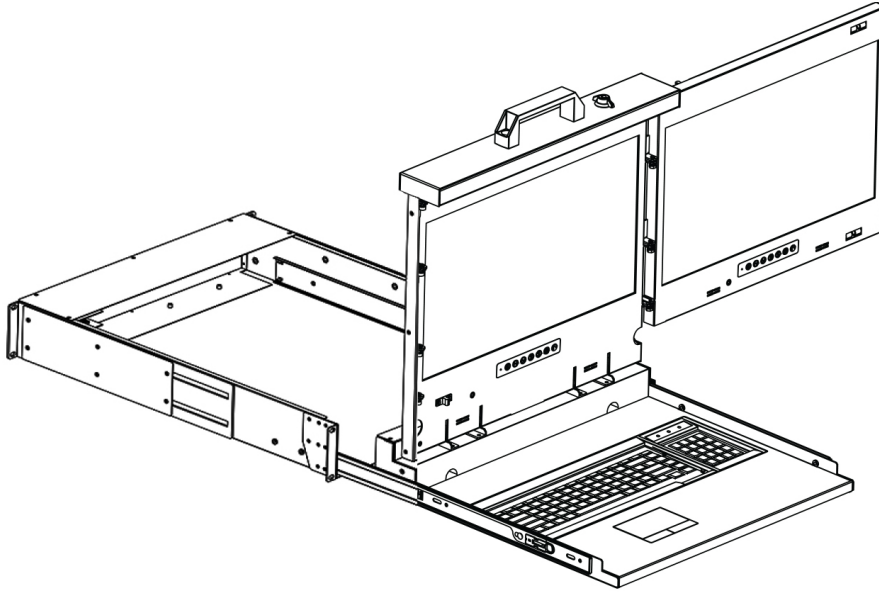

Drawing No.: NVP2D19e-R-KM-11042024-V1

Modified: 11-04-2024