

1U Rackmount 17" TFT LCD Monitor w/notebook keyboard & touch-pad mouse Drawer. (17.25"W x 18.1"D x 1.75"H) 1280x1024 Resolution, Video Input VGA and USB interface USB with NB-6A Cables x1pc (VGA+ 2x USB KVM Combo Cable 6ft long)

## MODEL: NVP117e



### BENEFITS:

- 1U 17" LCD console drawer
- 1280 x 1024 native resolution / 16.7M colors
- 104-key keyboard with either touchpad or trackball
- Short depth design of 460mm and 500mm respectively
- One Man installation design
- New enhanced aesthetics with molded front handle
- 2-year standard warranty (upgradable up to 5 years)

### OPTIONS:

- HDMI 1.4 + DVI-D + Audio in & out + Speakers ( AV4.4 )
- HDMI 1.4 + Speakers ( HDMI )
- S-Video + Composite + Speakers ( BNC )
- 3G / HD / SD-SDI Broadcast-grade input + Speakers ( SDI )
- Front USB hub port for device access ( USB )
- 2-post rack mounting brackets ( ORB-2.1 )
- DC power : 12V / 24V / 48V / 125V / 250V
- SUN Micro keyboard option
- 17" Touchscreen :  
Projected Capacitive 10-pt / Resistive 1-pt

### SPECIFICATIONS

| Console Port                  |  |
|-------------------------------|--|
| Video input                   | VGA  |
| KB / MS                       | USB interface  |
| VGA console 6ft cable : NB-6A | Drawer end : DB-15 + USB type A x 2<br>Server end : DB-15 + USB type A x 2 |

| LCD Panel                        |                        |
|----------------------------------|------------------------|
| Panel size ( diagonal )          | 17"                    |
| Native resolution                | 1280 x 1024            |
| Brightness ( cd/m <sup>2</sup> ) | 250                    |
| Contrast ratio ( typ. )          | 1000 : 1               |
| Colors                           | 16.7 M                 |
| Viewing angle ( L/R/U/D )        | 85/85/80/80            |
| Response time ( ms )             | 5                      |
| Dot pitch ( mm )                 | 0.264                  |
| Display area ( mm )              | 337.92H x 270.33V      |
| Surface treatment                | Haze 25%, Hard-coating |
| Surface hardness                 | 3H                     |
| Backlight type                   | LED                    |
| MTBF (hrs)                       | 30,000                 |

| Physical          |                                 |  |
|-------------------|---------------------------------|--|
| Product ( WxDxH ) | Single console                  | 442 x 460 x 44 mm<br>17.4 x 18.1 x 1.73 inch |
|                   | Console w/ KVM                  | 442 x 580 x 44mm<br>17.4 x 22.8 x 1.73 inch  |
| Packing ( WxDxH ) | Single console / Console w/ KVM | 590 x 815 x 140 mm<br>23.2 x 32.1 x 5.5 inch |
|                   | Net weight                      | Single console                               |
| Console w/ KVM    |                                 | 13 kg / 28.6 lb                              |
| Gross weight      | Single console                  | 16.6 kg / 36.5 lb                            |
|                   | Console w/ KVM                  | 19 kg / 41.8 lb                              |

| Mounting Distance     |                  |
|-----------------------|------------------|
| Single console drawer | 470 ~ 700 mm     |
| Console w/ KVM drawer | 18.5 ~ 27.6 inch |
| Console w/ KVM drawer | 470 ~ 800 mm     |
|                       | 18.5 ~ 31.5 inch |

| Video Option |                   |                     |
|--------------|-------------------|---------------------|
| Digital      | DVI               | DVI-D single link   |
|              | HDMI              | HDMI 1.4 / HDCP 1.4 |
| Analog       | S-Video ( 4-pin ) | NTSC & PAL          |
|              | Composite ( BNC ) | NTSC & PAL          |

#### HDMI

NVP117 chassis extension in depth to 480mm ( 18.9" )

#### S-Video & Composite

NVP117 chassis extension in depth to 530mm ( 20.9" )

| Audio Option |                          |                   |
|--------------|--------------------------|-------------------|
| Input        | Connector                | 3.5mm stereo jack |
|              | Impedance / Power level  | 30kΩ / 750mV      |
| Output       | Connector                | 3.5mm stereo jack |
|              | Resistance / Power level | 30kΩ / 2.8V       |
| Speaker      | Dual stereo              | 2W x 2            |

| Power                       |                                       |                     |
|-----------------------------|---------------------------------------|---------------------|
| Input                       | Auto-sensing 100 to 240VAC, 50 / 60Hz |                     |
| Consumption (console / KVM) | Screen on                             | Max. 22W / Max. 55W |
|                             | Power saving mode                     | Max. 2W / Max. 34W  |
|                             | Power button off                      | Max. 1W / Nil       |

| Environment            |                                    |
|------------------------|------------------------------------|
| Operating temp.        | -20 to 65°C degree                 |
| Storage temp.          | -20 to 65°C degree                 |
| Operating humidity     | 10~90%, non-condensing             |
| Storage humidity       | 5 ~90%, non-condensing             |
| Operating altitude     | 16,000 ft                          |
| Non-operating altitude | 40,000 ft                          |
| Shock                  | 10G acceleration ( 11ms duration ) |
| Vibration              | 10~300Hz 0.5G RMS random vibration |

| Compliance  |                      |
|-------------|----------------------|
| EMC         | FCC, CE certified    |
| Safety      | CE / LVD, UKCA & CCC |
| Environment | RoHS3 & REACH / WEEE |

## MODELS with KVM

|        |           |        |           |  |
|--------|-----------|--------|-----------|--|
| 2K KVM | <b>IP</b> | Remote | 8-port    |  |
|        | 0         | 0      | NVP117-D8 |  |

### 2K KVM Cable



NK6D (6 ft)  
DVI-D KVM cable



NK6H (6 ft)  
HDMI KVM cable

Resolution Support \*\*: 16:9 - max. 2560 x 1440  
16:10 - max. 1920 x 1200  
4:3 - max. 1600 x 1200

|           |           |        |            |  |
|-----------|-----------|--------|------------|--|
| DVI-D KVM | <b>IP</b> | Remote | 12-port    |  |
|           | 0         | 0      | NVP117-D12 |  |

### DVI-D USB KVM Cable

Resolution Support \*\*: 16:10 - max. 1920 x 1200  
16:9 - max. 1920 x 1080  
4:3 - max. 1600 x 1200



NI - 6 (6 ft)  
NI - 15 (15 ft)

|                    |           |        |        |               |               |
|--------------------|-----------|--------|--------|---------------|---------------|
| Matrix<br>CAT6 KVM | <b>IP</b> | Remote | 8-port | 16-port       | 32-port       |
|                    | 1         | 1      | -      | NVP117-MC1116 | NVP117-MC1132 |
|                    | 2         | 1      | -      | NVP117-MC2116 | NVP117-MC3224 |
|                    | 0         | 1      | -      | NVP117-MC0116 | NVP117-MC0132 |
|                    | 0         | 2      | -      | NVP117-MC0216 | NVP117-MC0232 |
|                    | 0         | 3      | -      | NVP117-MC0316 | NVP117-MC0332 |

### CAT6 KVM Dongle



USB-C dongle



IF-DUSBP  
DP - USB dongle



IF-DUSBH  
HDMI - USB dongle



IF-DUSBD  
DVI - USB dongle



IF-DUSB  
VGA - USB dongle

Resolution Support \*\*: 16:10 - max. 1920 x 1200  
16:9 - max. 1920 x 1080  
4:3 - max. 1600 x 1200

|                      |           |        |             |              |              |
|----------------------|-----------|--------|-------------|--------------|--------------|
| CAT6<br>Combo<br>KVM | <b>IP</b> | Remote | 8-port      | 16-port      | 32-port      |
|                      | 1         | 0      | NVP117-CIP8 | NVP117-CIP16 | NVP117-CIP32 |
|                      | 0         | 1      | NVP117-CCE8 | NVP117-CCE16 | NVP117-CCE32 |
|                      | 0         | 0      | NVP117-C8   | NVP117-C16   | NVP117-C32   |

|                     |           |        |             |              |
|---------------------|-----------|--------|-------------|--------------|
| Matrix<br>DB-15 KVM | <b>IP</b> | Remote | 8-port      | 16-port      |
|                     | 1         | 1      | NVP117-M118 | NVP117-M1116 |
|                     | 2         | 1      | NVP117-M218 | NVP117-M2116 |
|                     | 0         | 1      | NVP117-M018 | NVP117-M0116 |
|                     | 0         | 2      | NVP117-M028 | NVP117-M0216 |
|                     | 0         | 3      | NVP117-M038 | NVP117-M0316 |

### DB-15 VGA USB KVM Cable



NB - 6 (6 ft)



NB - 10 (10 ft)





NB - 15 (15 ft)

Resolution Support \*\*: 16:10 - max. 1920 x 1200  
16:9 - max. 1920 x 1080  
4:3 - max. 1600 x 1200

|                    |           |        |            |             |
|--------------------|-----------|--------|------------|-------------|
| Combo<br>DB-15 KVM | <b>IP</b> | Remote | 8-port     | 16-port     |
|                    | 1         | 0      | NVP117-IP8 | NVP117-IP16 |
|                    | 0         | 1      | NVP117-CE8 | NVP117-CE8  |
|                    | 0         | 0      | NVP117-S8  | NVP117-S16  |

## IP Console







**High Performance KVM Access Over IP**

Connector : RJ45  
 User management: 1 x active user, 15-user login  
 Network protocol: DHCP / BOOTP / DNS  
 Security : TLS 1.3, AES, LDAP, Active Directory (AD), HTTP(s)  
 Browser : Chrome, Firefox, Edge, etc.  
 Resolution : 16:9 - max. 1920x1080 / 16:10 - max. 1920x1200 / 4:3 - max. 1600x1200

## STANDARD KEYBOARD



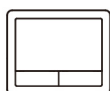
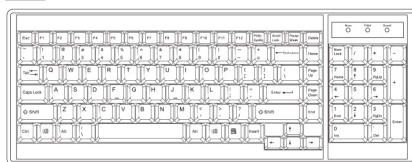



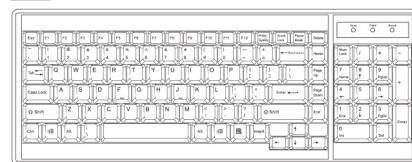

**Ge** G keyboard with touchpad



**Gb** G keyboard with trackball



### Supporting layouts

|         |   |   |   |   |   |   |
|---------|---|---|---|---|---|---|
| America |  |   |   |   |   |   |
|         | U.S.  |   |   |   |   |   |
| EMEA    |  |  |  |  |  |  |
|         | U.K.  | Germany   | France  | Russia  | Spain   | Italy   |
| Asia    |  |  |   |   |   |   |
|         | Japan   | Korea   |   |   |   |   |

## KEYBOARD OPTIONS

\* US layout only

**Me** Mac keyboard with touchpad



**Se** S keyboard with touchpad

**Mb** Mac keyboard with trackball

**Sb** S keyboard with trackball



## STRUCTURE DIAGRAM

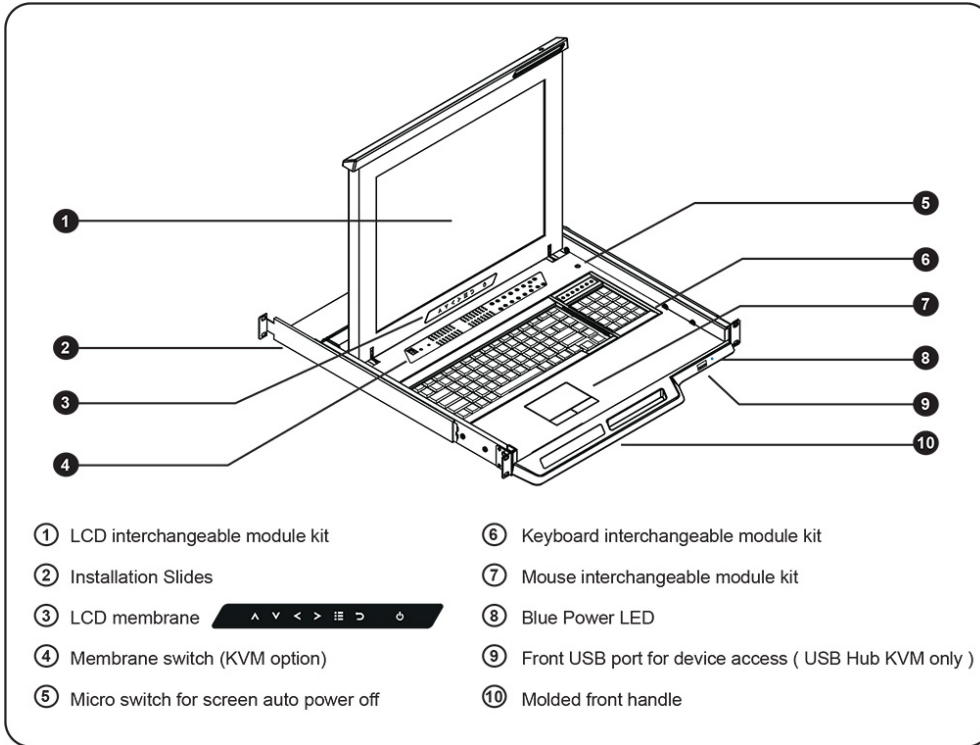

## DIMENSION

*This is subject to change without Notice. Final Drawings Will be Provided for Approval after Order.*

### Front View

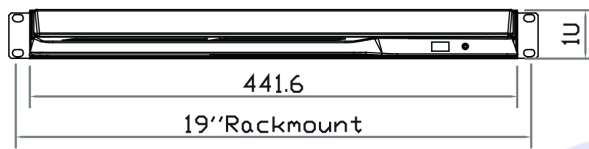

### Rear View

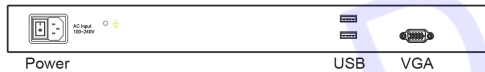

### Side View

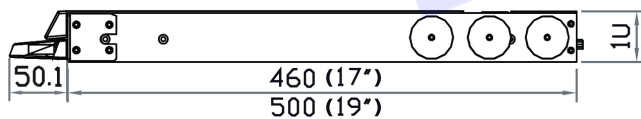

### Top View

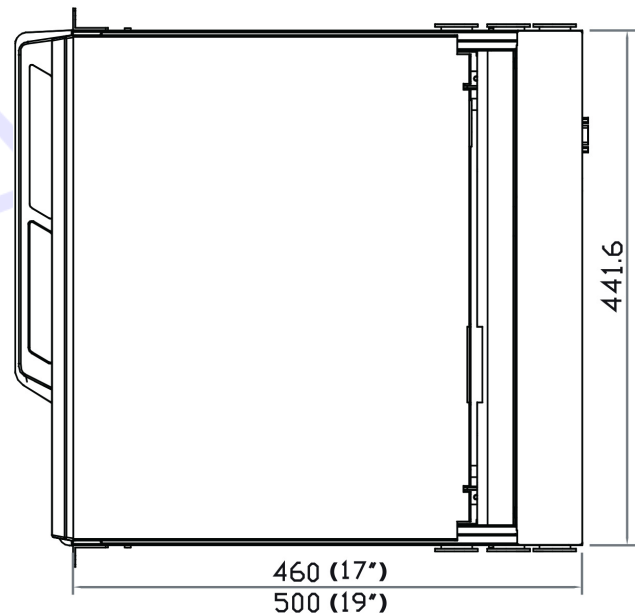

Drawing No.: NVP117e-05052022-V1

**ACTUAL PICTURES – 04/15/25**



Reference: SO# 121192