

9U 20" TFT LCD Rackmount Monitor Flat Panel, Resolution 1600x1200, HDMI-1.2 + Audio + VGA + Built in Speakers.  
+ Integrated One Point e-Resistive Touch Screen with USB Controller.

## MODEL: NP920-HDMI-TRB-USB



### BENEFITS:

- 9U 20" LCD display panel
- 1600 x 1200 native resolution / 16.7M colors
- HDMI + VGA video input
- 2-year standard warranty ( upgradable up to 5 years )

### SPECIFICATIONS:

Video	
Video input	VGA + HDMI

LCD Panel	
Panel size ( diagonal )	20.1"
Native resolution	1600 x 1200
Brightness ( cd/m <sup>2</sup> )	300
Contrast ratio ( typ. )	800 : 1
Colors	16.7 M
Viewing angle ( L/R/U/D )	89/89/89/89
Response time ( ms )	16
Dot pitch ( mm )	0.255
Display area ( mm )	408H x 306V
Surface treatment	Anti-glare, Hard-coating
Surface hardness	3H
Backlight type	LED
MTBF (hrs)	45,000

Physical		
Dimensions ( W x D x H )	Product	480 x 64 x 399 mm 18.9 x 2.5 x 15.7 inch
	Packing	583 x 124 x 529 mm 23 x 4.9 x 20.8 inch
Weight	Net	8.5 kg / 18.7 lb
	Gross	11 kg / 24.2 lb

Power		
Input	Auto-sensing 100 to 240VAC, 50 / 60Hz	
Consumption	Screen on	Max. 45W
	Power saving mode	Max. 2W
	Power button off	Max. 1W

\*Specifications subject to change without notice, not responsible for typographical errors.

### OPTIONS:

- HDMI 1.2 + Audio input & output
- Audio input & output
- 3G / HD / SD-SDI Broadcast-grade input
- Multi display OSD controller
- MIL-type or lockable connector
- IP65 front protection
- DC power : 12V / 24V / 48V / 125V / 250V  
Touchscreen : Resistive 1-pt

Video Option		
Digital	HDMI	HDMI 1.2 / HDCP 1.1

Audio Option		
Input	Connector	3.5mm stereo jack
	Impedance / Power level	30kQ / 750mV
Output	Connector	3.5mm stereo jack
	Resistance / Power level	30kQ / 2.8V
Speaker	Dual stereo	2W x 2

Environment	
Operating temp.	0 to 55°C degree
Storage temp.	-20 to 60°C degree
Operating humidity	10~90%, non-condensing
Storage humidity	5 ~90%, non-condensing
Operating altitude	16,000 ft
Non-operating altitude	40,000 ft
Shock	10G acceleration ( 11ms duration )
Vibration	10~300Hz 0.5G RMS random vibration

Compliance	
EMC	FCC, CE
Safety	CE / LVD & UKCA
Environment	RoHS3 & REACH / WEEE

# STRUCTURE DIAGRAM

## Front view

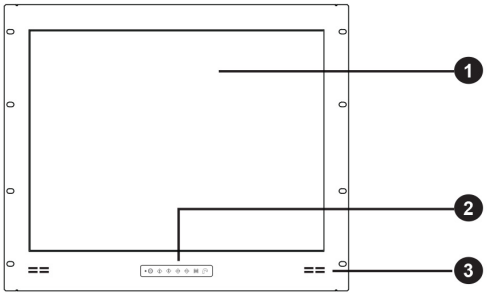

- ① LCD panel
- ② LCD membrane
- ③ Audio speaker
- ④ Power adapter basket

## Rear view

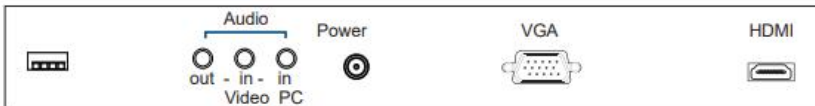
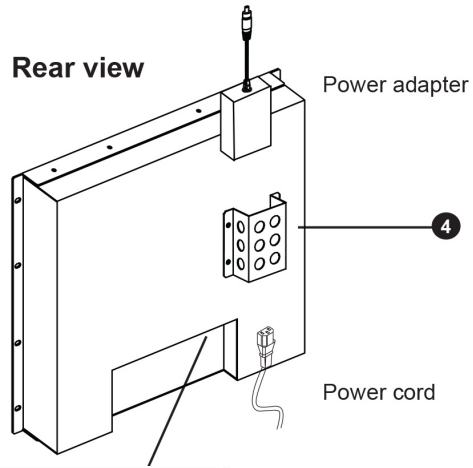

# DIMENSION

This is subject to change without Notice. Final Drawings Will be Provided for Approval after Order.

## Front View

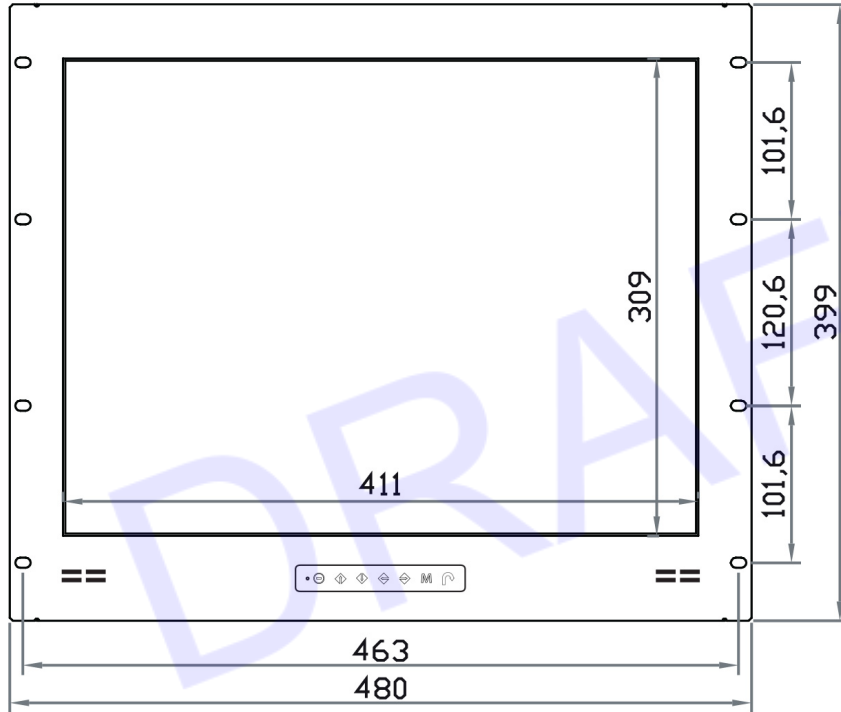

## Side View

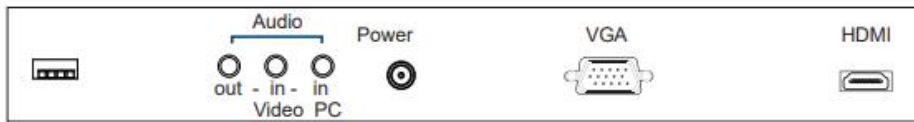
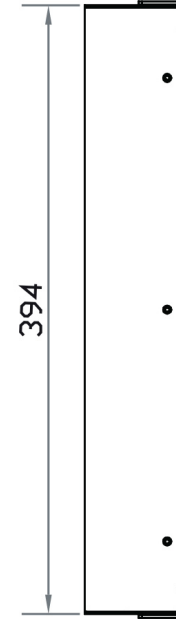

## Bottom View

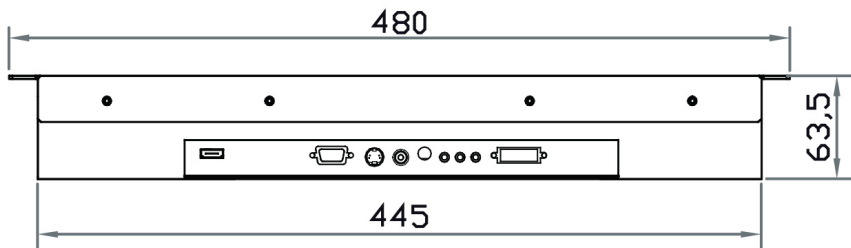

UNIT : mm  
1mm = 0.03937 inch

Drawing No.: NP920-HDMI-TRB-USB-06022023-V1