

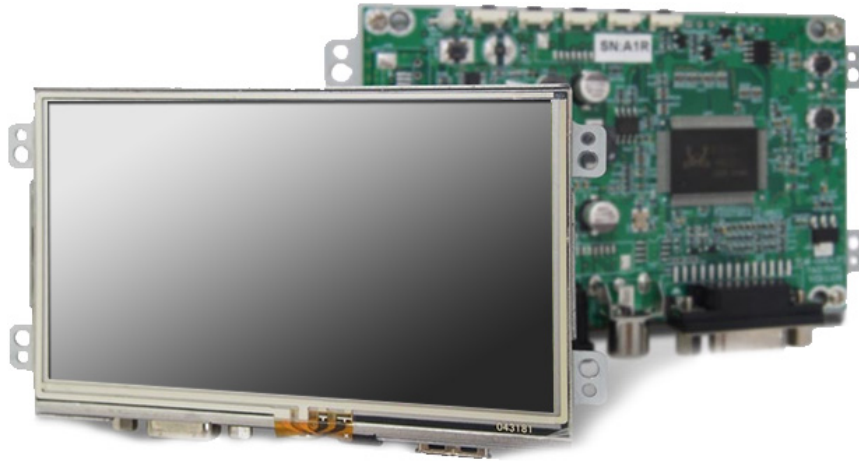

## SPECIFICATION APPROVAL SHEET

4.3" Digital TFT-LCD Module

**MODEL: FCOP0430**



## ***1. General Description***

### ***1.1 Features***

- 4.3" (480x272) Digital TFT LCD
- Aspect Ratio: 16:9
- Input Signal CVBS / VGA
- Maximum Support Resolution 1920x1080
- 4 Wires Resistive Touch Panel
- 5 Key Buttons Controls
- 9 Language OSD Menu
- LED Backlight
- Single Operation Voltage +12V

### ***1.2 Applications***

- Industrial
- Medical Environment
- Instrument Display
- Kiosk
- Security
- Signage
- Office Electronics
- Home Application
- Educate Application

## 2. Contents

Contents	Page
<b>1. General Description.....</b>	<b>1</b>
1.1 Features	1
1.2 Applications	1
<b>2. Contents.....</b>	<b>2-3</b>
<b>3. Specifications.....</b>	<b>4</b>
<b>4. Block Diagram.....</b>	<b>4</b>
<b>5. Order Information.....</b>	<b>5-6</b>
5.1 Unit	5-6
5.2 Customized	6
5.3 Demo Board (Option)	6
<b>6. Accessories (Option).....</b>	<b>7</b>
<b>7. Operation manual / Connection.....</b>	<b>8</b>
7.1 Driver Board Manual	8
<b>8. Pin Description.....</b>	<b>9-11</b>
8.1 J105 : Pin Assignment of Analog RGB Input ( D-Sub 15Pin)	9
8.2 J103: Pin Assignment of UART (Pitch 1.25mm 4Pin, Top Entry Type)	9
8.3 DC JACK: Pin Assignment of Power Input (Inside Diameter:2.1 $\psi$ Outside Diameter:5.5 $\psi$ Side Entry Type)	10
8.4 RCA: Pin Assignment of Video Input (RCA JACK Yellow, Side Entry Type)	10
8.5 J402 : Pin Assignment of Touch USB (USBA-Female, Side Entry Type )(Option)	10
8.6 J404 : Pin Assignment of Touch RS232 (D-SUB 9 FEMALE)(Option)	10
8.7 J102 : Pin Assignment of Analog RGB Input (Pitch 2.0mm 14Pin, Side Entry Type)	11
8.8 J101 : Pin Assignment of Signal Input (Pitch 1.25mm 8Pin, Side Entry Type)	11
8.9 J401 : Pin Assignment of Touch (Pitch 2.0mm 4Pin, Side Entry Type)	11
<b>9. Absolute Maximum Ratings.....</b>	<b>12</b>
9.1 Absolute Maximum Ratings	12
<b>10. Recommended Operating Conditions.....</b>	<b>12</b>
10.1 Electrical Characteristics	12
10.2 Support Display Mode Characteristics	12
<b>11. 4W Resistance Touch Panel Characteristics.....</b>	<b>13-16</b>
11.1 Electrical Performance	13
11.2 Mechanical Performance	13
11.3 Durability Performance	13
11.4 Touch Panel Operation System Support	14
11.5 Touch Screen Integration Design Guide	15
11.6 Mechanical Design Notice For Touch Panel	16
<b>12. Key Function by OSD.....</b>	<b>17-21</b>

12.1 Menu Operation	17-21
<b>13. Dimension Information.....</b>	<b>22-23</b>
13.1 Unit (FCOP0430)	22
13.2 Unit (FCOP0430-TR)	23
<b>14. Appendix.....</b>	<b>24-31</b>
14.1 TFT-LCD Mechanical Specifications	24
14.2 TFT-LCD Optical Characteristics	24
14.3 Application Circuit	25
14.4 Board	26
14.5 (Option)	27
14.6 (Option)	28
14.7 Cable: 8P-8P 1.25mm L:100mm (Option)	29
14.8 Cable: 14P-14P 2.0mm L:110mm (Option)	30

### 3. Specifications

LCD	
Panel Size	4.3"
Resolution (Pixels)	480x272
Color	16.2M
Luminance without TP	500 cd/m <sup>2</sup>
Luminance (RTP)	400 cd/m <sup>2</sup>
Contrast Ratio	500
Viewing Angle	70(L) / 70(R) / 50(T) / 70(B)
LED Life Time (Min.)	20K hours
Power Requirement	
Power Input (DC Jack 2.1 φ)	+12Vdc
Power Consumption	2.28
Touch Screen	
Resistive Type	USB / RS232 Interface
Resistive Type Support OS	Windows / Linux / DOS / Mac / QNX

Input Signal		
CVBS	RCA JACK	
VGA	D-Sub15	
Controls		
Key	5 Buttons	
Serial Remote Control	UART / RS232 (Option)	
Environment		
	Without TP	4W RTP
Operating Temp.	-20~+70°C	-20~+70°C
Storage Temp.	-20~+70°C	-20~+70°C
High Temperature & High Humidity (Non-condensing)	+60°C / 90%	+60°C / 90%

### 4. Block Diagram

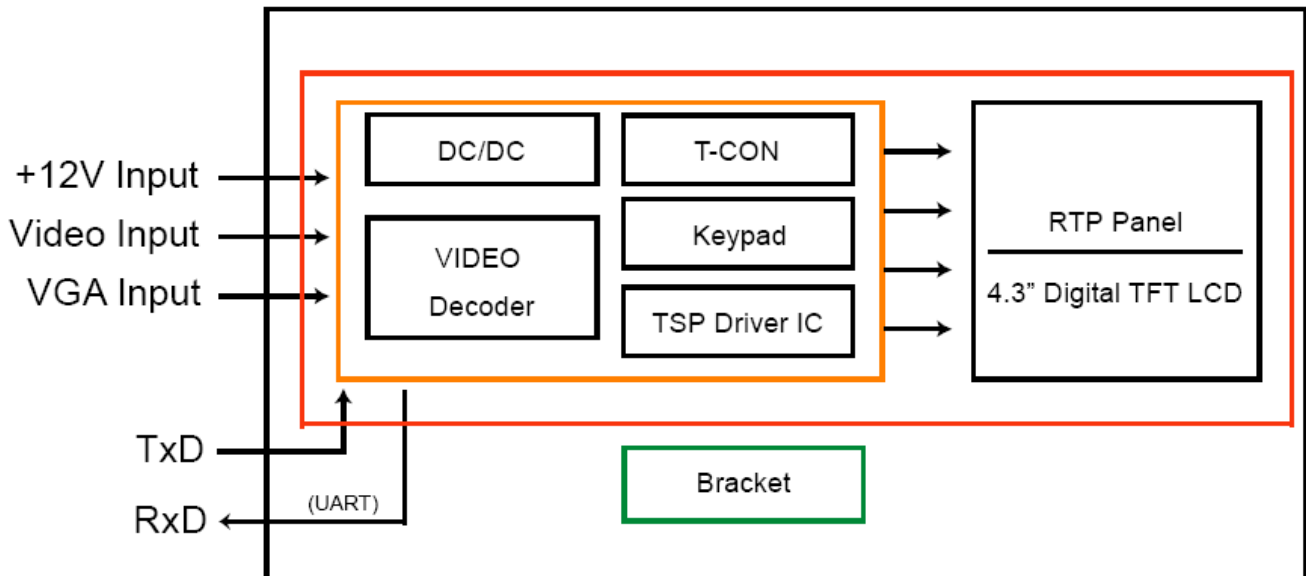

## 5. Order Information

### 5.1 Unit

Item	FCOP0430	FCOP0430-TR		Unit	Remark
CVBS	◎	◎			
Power Connector (Dc Jack/CON. 1.25mm 8Pin)	Dc Jack	Dc Jack			
VGA (D-Sub15/CON. 2.0mm 14Pin)	D-Sub15	D-Sub15			
Touch Panel Type	-	4W Resistive			
Touch Screen Interface	-	USB			
Serial Remote Control	UART	UART			
Dimension	118.5 x 69 x 20.4	118.5 x 69 x 21.55		mm	
Weight	122.5	135.5		g	±10%
Condition	Standard	Standard			

Note: 1.The assembling of panel and bracket is aimed for delivery, packaging and experiment. If the demand of shockproof and long-term fix, pls have it into consideration of mechanism design.

**5.2 Customized**

Function	Item
Serial Remote Control	RS232 (DB9)
External Key	5 keys

**Note:** Special order condition will apply to non-standard items and pls. contact salespersons in iTech.

**5.3 Demo Board (Option)**

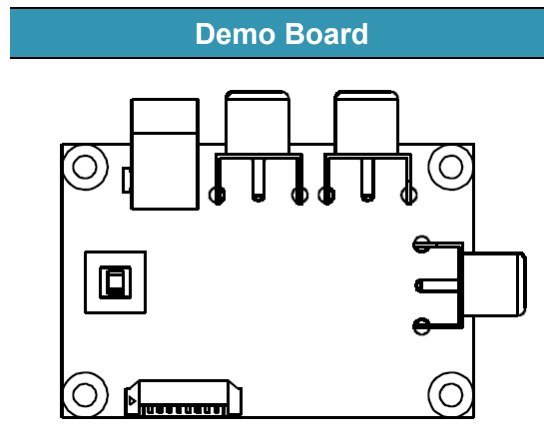

Order Part Number	Part Number	Remark
	Cable: 8P-8P 1.25mm L:100mm	

## 6. Accessories (Option)

Before you begin installing the KIT, please make sure that the following materials have been shipped:



A.



B.



C.



D.



E.



F.



G.

- A. AC to DC Adapter (L:1500mm, 100-240VAC 50-60Hz to +12VDC @ 3.3A)
- B. Power Cord (L:1800mm, Plug Type B for USA)
- C. Video Cable (L:1800mm)
- D. VGA Cable (L:1800mm)
- E. USB Cable (L:1800mm)
- F. RS232 Cable (L:1800mm)
- G. Touch Screen Driver CD Disk / User Manual



## 7 Operation manual / Connection

### 7.1 Driver Board Manual

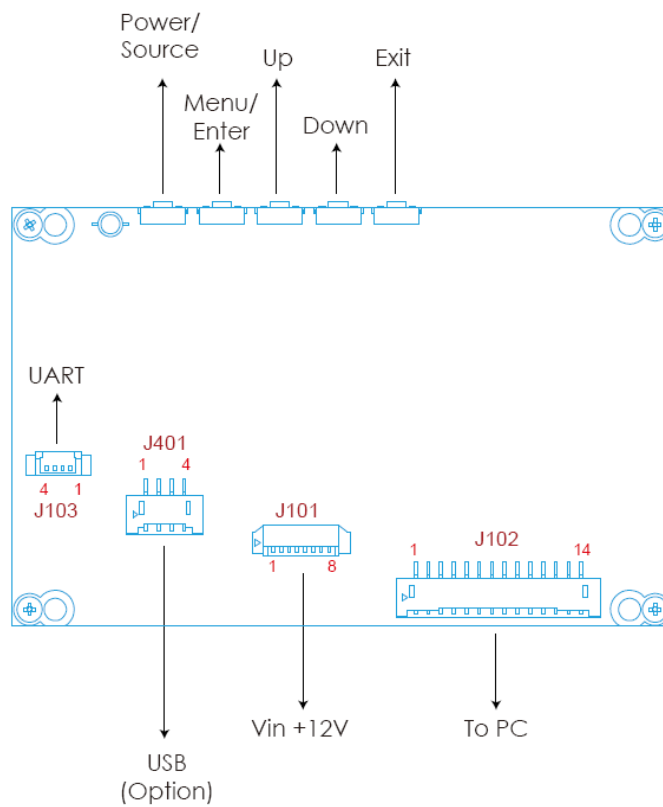
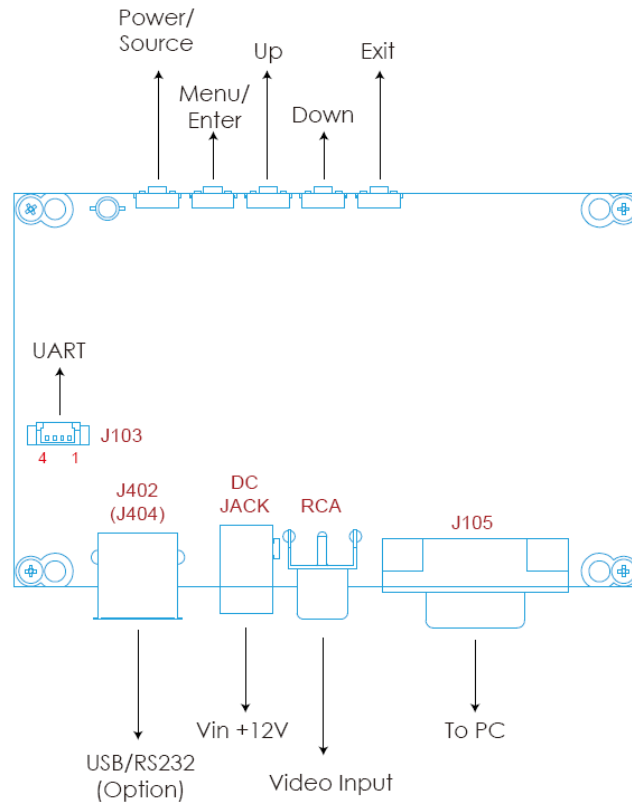

## 8. Pin Description

### 8.1 J105 : Pin Assignment of Analog RGB Input ( D-Sub 15Pin)

Pin No.	Symbol	I/O	Description	Remark
1	RI+	I	Analog Red Signal	
2	GI+	I	Analog Green Signal	
3	BI+	I	Analog Blue Signal	
4	NC	-	No Connection	
5	GND	-	Ground	
6	AGND	-	Analog Ground	
7	AGND	-	Analog Ground	
8	AGND	-	Analog Ground	
9	NC	-	No Connection	
10	NC	-	No Connection	
11	NC	-	No Connection	
12	NC	-	No Connection	
13	HS_IN	I	TTL Horizontal sync	
14	VS_IN	I	TTL Vertical sync	
15	NC	-	No Connection	

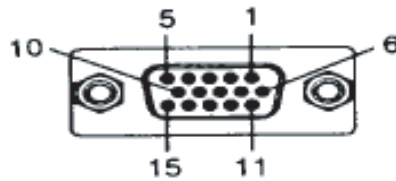

### 8.2 J103: Pin Assignment of UART (Pitch 1.25mm 4Pin, Top Entry Type)

※ Connector Part No.: MS24014 (STM) [Same as 53398-0471 (MOLEX)] ;

※ Matching Connector Part No.: P24014 (STM) [Same as 51021-0400 (MOLEX)].

Pin No.	Symbol	I/O	Description	Remark
1	TX / RS232 TX (Option)	O	UART / RS232 (Option) Transmission Data	
2	RX / RS232 RX (Option)	I	UART / RS232 (Option) Receive Data	
3	GND	-	Ground	
4	+3.3Vdc	O	+3.3Vdc Output Voltage	

**Note: All Functions can be controlled by UART , About UART command list please contact iTech sales.**

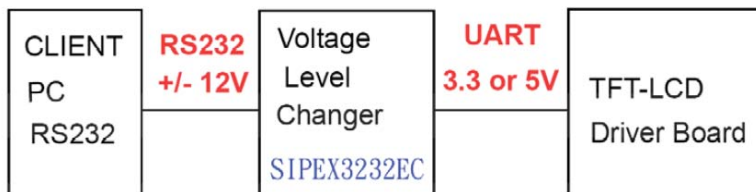

**8.3 DC JACK: Pin Assignment of Power Input (Inside Diameter:2.1 ϕOutside Diameter:5.5 ϕSide Entry Type)**

Pin No.	Symbol	I/O	Description	Remark
1	VIN	I	+12V Input Voltage	
2	GND	-	Power Ground	

**8.4 RCA: Pin Assignment of Video Input (RCA JACK Yellow, Side Entry Type)**

※ Connector Part No.: MS240112R (STM) [Same as 53261-1219 (MOLEX)] ;

※ Matching Connector Part No.: P240112 (STM) [Same as 51021-1200 (MOLEX)].

Pin No.	Symbol	I/O	Description	Remark
1	Video	I	Video Input	
2	AGND	-	Analog Ground	

**8.5 J402 : Pin Assignment of Touch USB (USBA-Female, Side Entry Type )(Option)**

Pin No.	Symbol	I/O	Description	Remark
1	VBUS	-	USB VCC	
2	D-	-	DATA (-)	
3	D+	-	DATA (+)	
4	DGND	-	Digital Ground	

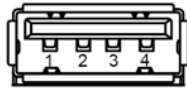

**8.6 J404 : Pin Assignment of Touch RS232 (D-SUB 9 FEMALE)(Option)**

Pin No.	Symbol	I/O	Description	Remark
1	NC	-	No Connection	
2	TXD	-	Transmit Data	
3	TXD	-	Receive Data	
4	NC	-	No Connection	
5	GND	-	Ground	
6	NC	-	No Connection	
7	NC	-	No Connection	
8	NC	-	No Connection	
9	NC	-	No Connection	

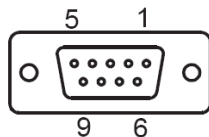

**8.7 J102 : Pin Assignment of Analog RGB Input (Pitch 2.0mm 14Pin, Side Entry Type)**

※ Connector Part No.: MS242614R (STM) [Same as S14B-PH-K-S (JST)] ;

Matching Connector Part No.: P242614 (STM) [Same as PHR-14 (JST)].

Pin No.	Symbol	I/O	Description	Remark
1	NC	-	No Connect	
2	NC	-	No Connect	
3	NC	-	No Connect	
4	GND	-	Ground	
5	NC	-	No Connect	
6	VS_IN	I	TTL Vertical sync.	
7	HS_IN	I	TTL Horizontal sync.	
8	AGND	-	Analog Ground	
9	RI+	I	Analog Red Signal	
10	AGND	-	Analog Ground	
11	GI+	I	Analog Green Signal	
12	AGND	-	Analog Ground	
13	BI+	I	Analog Blue Signal	
14	GND	-	Ground	

**8.8 J101 : Pin Assignment of Signal Input (Pitch 1.25mm 8Pin, Side Entry Type)**

※ Connector Part No.: MS24018R (STM) [Same as 53261-0819 (MOLEX)] ;

Matching Connector Part No.: P24018 (STM) [Same as 51021-0800 (MOLEX)]

Pin No.	Symbol	I/O	Description	Remark
1	VCC12V	-	+12V Input Voltage	
2	VCC12V	-	+12V Input Voltage	
3	GND_D	-	Ground	
4	GND_D	-	Ground	
5	VIDEO1	I	Video1 Input Signal	
6	GND_A	-	Ground For Video1	
7	VIDEO2	I	Video2 Input Signal	
8	GND_A	-	Ground For Video2	

**8.9 J401 : Pin Assignment of Touch (Pitch 2.0mm 4Pin, Side Entry Type)**

※ Connector Part No.: M24264R (STM) [Same as S4B-PH-K-S (JST)] ;

Matching Connector Part No.: P24264 (STM) [Same as PHR-4 (JST)].

Pin No.	Symbol	I/O	Description	Remark
1	VBUS	-	USB VCC/No Connection	
2	D-/RXD	-	DATA (-)/Receive Data	
3	D-/TXD	-	DATA (+)/Transmit Data	
4	DGND	-	Digital Ground	

## 9. Absolute Maximum Ratings

### 9.1 Absolute Maximum Ratings

Parameter	Symbol	Min	Max	Unit	Remark
Input Voltage	V <sub>in</sub>	9	15	V	
Video Input Signal	Video in	0.5	2.0	V <sub>p-p</sub>	@75Ω
Analog RGB Input Signal	Analog RGB in	0.5	2.0	V <sub>p-p</sub>	@75Ω
Digital Input Signal	TTL	+0.3	+3.6	V	
Operating Temperature without TP		-20	+70	°C	
Operating Temperature with RTP		-20	+70	°C	
Storage Temperature without TP		-30	+80	°C	
Storage Temperature with RTP		-30	+80	°C	
High Temperature & High Humidity (Non-condensing) without TP		-	+60 / 90	°C / %	
High Temperature & High Humidity (Non-condensing) with RTP		-	+60 / 90	°C / %	

## 10. Recommended Operating Conditions

### 10.1 Electrical Characteristics

Parameter	Symbol	I/O	Min	Typ	Max	Unit	Note
Input Voltage	V <sub>in</sub>	I	+10	+12	+14	V	
Total Current	I <sub>in</sub> (+12V)	I	-	190	-	mA	±15%
Power Consumption		I	-	2.28	-	W	@+12V
Output Voltage	V <sub>DD</sub>	O	+3.2	+3.3	+3.4	V	I=10mA
Video Input Signal	Video in	I	-	1.0	-	V <sub>p-p</sub>	@75Ω
Analog RGB Input Signal	Analog RGB in	I	-	0.7	-	V <sub>p-p</sub>	@75Ω

### 10.2 Support Display Mode Characteristics

Dots per inch	Standard	H	Unit	Polarity	V	Unit	Polarity	Note
640 × 480	-	31.469	KHz	Negative	59.941	Hz	Negative	
800 × 600	VESA	37.879	KHz	Positive	60.317	Hz	Positive	
1024 × 768	VESA	48.363	KHz	Negative	60.004	Hz	Negative	

Note: Polarity & standard only for VGA mode

## 11. 4W Resistance Touch Panel Characteristics

### 11.1 Electrical Performance

Parameter	Symbol	Min	Typ	Max	Unit	Remark
Terminal Resistance	X	300		1500	$\Omega$	
	Y	100		900	$\Omega$	
Linearity		-1.5	-	1.5	%	
Insulation Impedance		25	-	-	M $\Omega$	DC 25V
Response Time		-	-	20	ms	

### 11.2 Mechanical Performance

Parameter	Specifications	Remark
Input Method	Finger or stylus pen	
Operating Force	80g Min.	
Surface Hardness	3H or more	

### 11.3 Durability Performance

Parameter	Specifications
Hitting Durability	$\geq$ 1000000 times, with R8.0 mm silicon rubber, 200g, 2 times/sec
Sliding Durability	$\geq$ 100000 words, with R0.8 mm polyacetal stylus, 250g, 60 mm/sec

**11.4 Touch Panel Operation System Support**

**Driver Vender : ITE (ITE Tech. Inc.)**

OS	Version	Interface
<b>Windows</b>	Windows 7, 8, 8.1, 10	USB/RS232
	Windows Embedded 7, 8	
	Windows Embedded POSReady 2009, POSReady 7	
	Embedded Standard 7	
	Embedded Enterprise 7	
	Embedded 8 Standard	
	Embedded 8.1 Pro/ Embedded 8.1 Industry	
	Windows , XP, 2000	
Windows XP Embedded		
<b>Windows CE</b>	Windows Embedded Compact 2013, 7	USB/RS232
	Windows CE 6.0	
	Windows CE.Net (4.x / 5.0)	
<b>Linux</b>	Kernel 2.6.24 Upward and 3.x.x / 4.x.x / 5.x.x (X86 / ARM / MIPS)	USB
	Kernel 2.6.23 Downward (X86)	
	Kernel 2.4.x (x86)	
<b>Android</b>	Android Version 2.3.x upwards (X86 / ARM / MIPS)	USB
<b>Mac OS</b>	Mac OS X 10.5.3 Leopard (Power PC)	USB
	Mac OS X 10.7.4 Earlier (32Bit / 64Bit) (Intel CPU)	
	Mac OS X 10.7.5 (32Bit / 64Bit) (Intel CPU)	
	Mac OS X 10.8.x Mountain Lion (Intel CPU)	
	Mac OS X 10.9.x Mavericks (Intel CPU)	
	Mac OS X 10.10.x Yosemite (Intel CPU)	
	Mac OS X 10.11 El Capitan (Intel CPU)	
	Mac OS 10.12 Sierra (Intel CPU)	
	Mac OS 10.13 High Sierra (Intel CPU)	
	Mac OS 10.14 Mojave (Intel CPU)	
	Mac OS 10.15 Catalina (Intel CPU)	
<b>QNX</b>	QNX Neutrino RTOS V6.5/6.4	USB/RS232
	QNX Neutrino RTOS V6.3	

**Note: 1. Please refer to the iTech website for the driver installation and support operating system.**

**2. How to use Touch Driver , please refer to Readme of Touch Screen Driver CD Disk.**

**3. Please refer to the iTech website for the latest driver version and support operating system.**

### 11.5 Touch Screen Integration Design Guide

Front case design follow as below

1. Avoid the design that front case overlap and press on the active area of the LCM.
2. Give enough gap(over 0.5mm at compressed) between the front case and TSP to protect wrong operating.

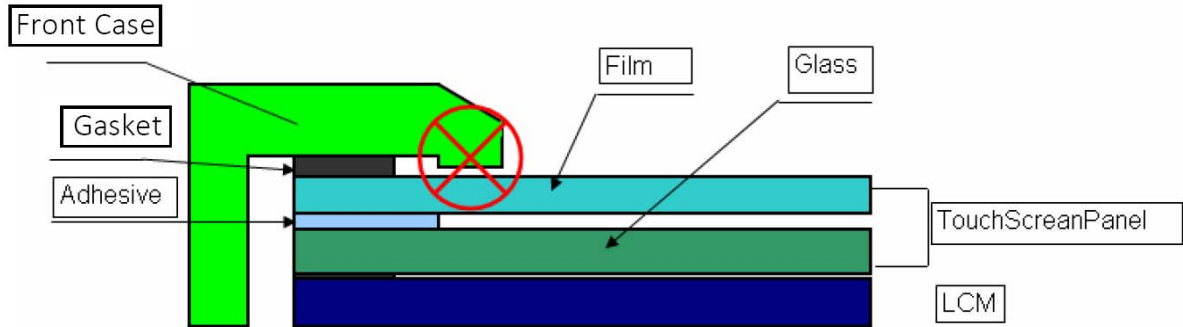

3. Use a buffer material(Gasket) between the TSP and front case to protect damage and wrong operating.
4. Avoid the design that buffer material overlap and press on the inside of TSP view area.

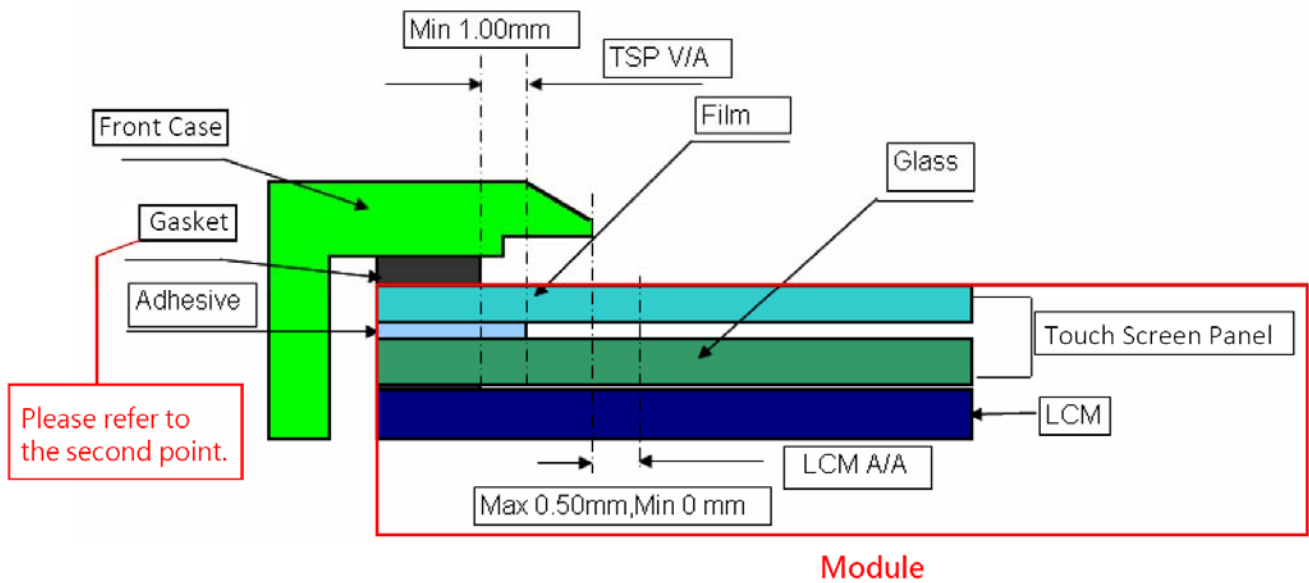



**11.6 Mechanical Design Notice For Touch Panel**

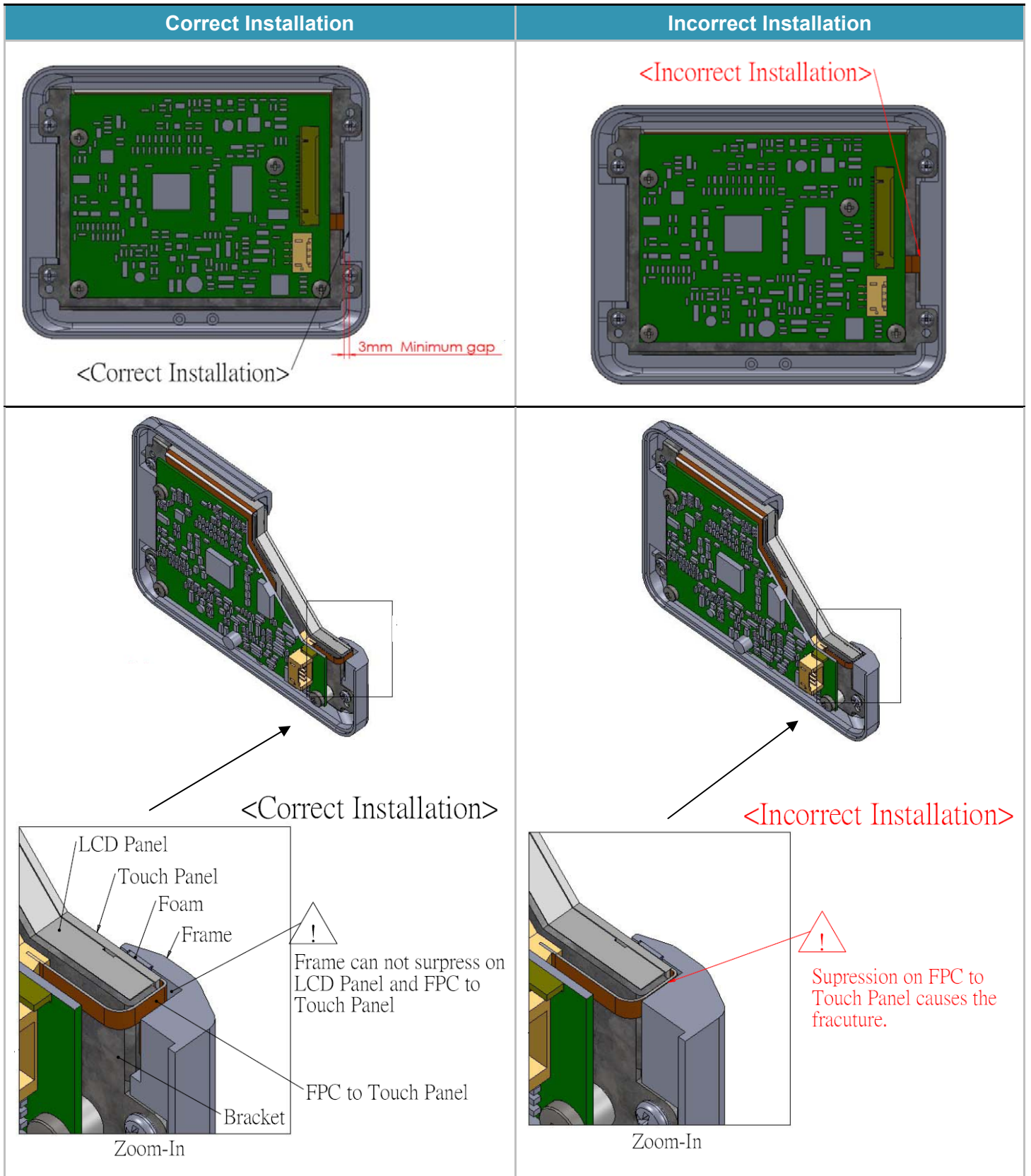

## 12. Key Function by OSD

### 12.1 Menu Operation

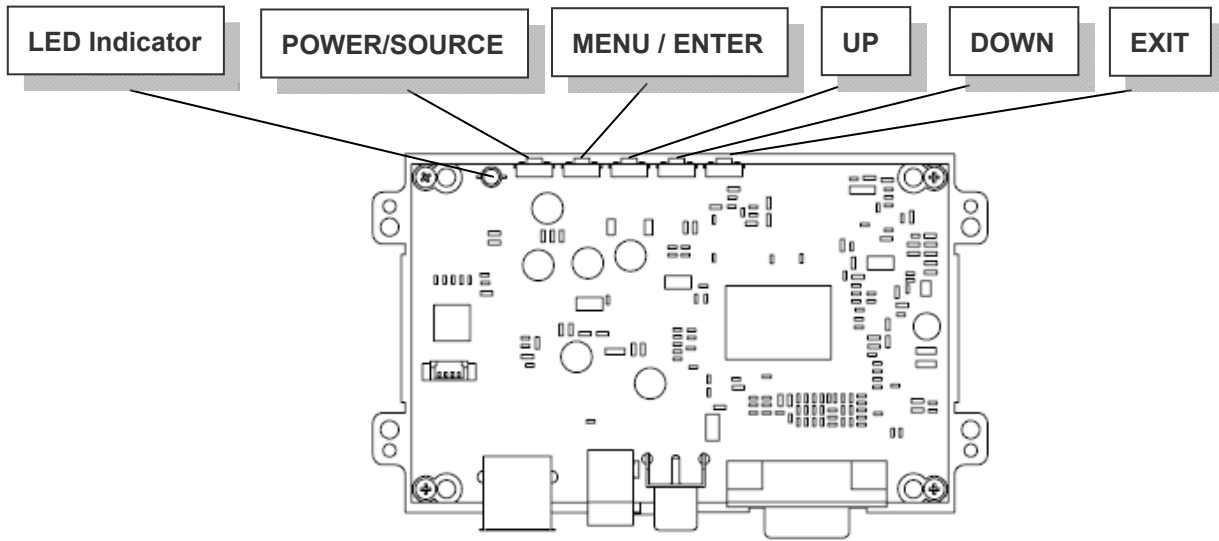

### OSD ICON Instructions :

1. POWER / SOURCE : Power On/Off (※Press for 3 secs to turn off)
2. MENU / ENTER : (After turning on MENU, only ENTER is available)
3. UP : Move Upward / Increase Value / Option Switch
4. DOWN : Move Downward / Decrease Value / Option Switch
5. EXIT : Return to Previous Page
6. LED Indicator
  - Waiting : Flickering Green
  - Power ON : Green
  - Power OFF : Red

### Save OSD Setting:

1. EXIT MENU and settings will be saved automatically
2. Settings will be saved as well when MENU shuts down automatically

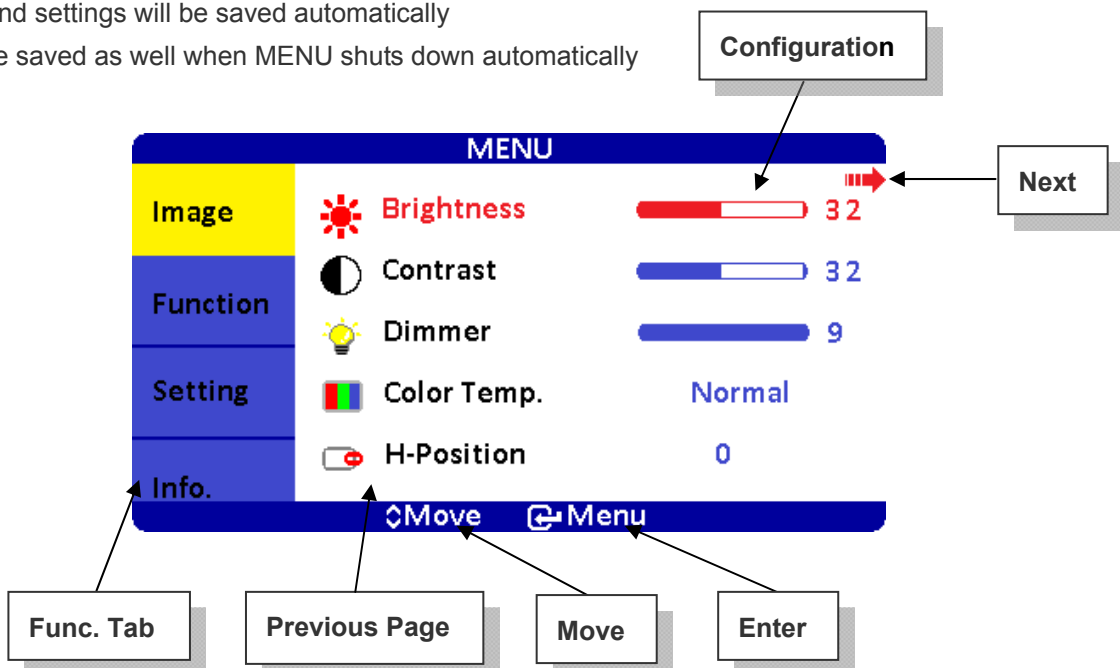

## Overview of the Menu :



### Image (VGA)

Indicator	Meaning	Default	Adjustable range	Remark
	Brightness	32	0~63	Adjust-Bar
	Contrast	32	0~63	Adjust-Bar
	Dimmer	9	0~9	Adjust-Bar
	Color Temp.	Normal	Normal / Warm / Cool	For VGA System Only
	H-Position	0	The adjusting value range depends on each resolution mode	
	V-Position	0	The adjusting value range depends on each resolution mode	
	Clock	0	-49~+49	
	Phase	0	0~63	
	Auto	Depend on the Signal		
	Exit			



### Image (Video)

Indicator	Meaning	Default	Adjustable range	Remark
	Brightness	22	0~63	Adjust-Bar
	Contrast	40	0~63	Adjust-Bar
	Color	50	0~63	Adjust-Bar
	Tint	16	0~31	For NTSC System Only
	Sharpness	8	0~15	Adjust-Bar
	Dimmer	9	0~9	Adjust-Bar
	Exit			









## Function

ICON	Meaning	Function	Default	Status	Description	Remark
	Show Status	Information of input source	On	On	Show input source	
				Off	Hide input source	
	Blue Screen	Select blue/ black screen when no input signal is detected.	On	On	Show blue screen when no input.	
				Off	Show black screen when no input.	
	Auto Power On	Modules turns on automatically without power key input.	On	On	Auto	
				Off	Manual	
				Auto Save	Power off , the last state	
	Detect Source	Auto detect input source.	On	On	Auto-detect signal source	
				Off	Manual switch signal source	
	Auto Power Saving	Modules go standby when no input source is detected.	Off	6s / 15s / 30s	Go standby by settings when no input	LED indicator: Flickering Green
				Off	Show no signal when no input	LED indicator: Green
	Auto Sleep	Modules go off when set timing is out.	Off	15M / 30M / 60M	Go off by time setting	LED indicator: Red Press Power Key back to life.
				Off	Turn off sleep mode	
	Exit					

**Note : After configuration is set, RESET won't restore to default setting.**

 **Setting**

Indicator	Meaning	Default	Adjustable range	Remark
	Aspect Ratio	Full	Full/4:3	CVBS & Wide-panel only Note 1
	Scan	Under Scan	Over Scan/Under Scan	CVBS Only, Note 1
	Language	English	English / 中文 / 日本語 / 한국의 / Française / Deutsch / Italiano / Española / Português	Note 1
	OSD Transparent	0	0~7	Menu Transparent
	Reset			Restore to default
	Exit			

**Note 1: Press MENU to store changes when OSD adjustment is done.**

 **Info.**

MENU	
Image	Source : VGA Resolution : 1024x768
Function	H.Freq : 48.2KHz V.Freq : 59.8Hz
Setting	Program Ver : 2.00 Command Ver : 2.00
Info.	
◀ Move    ▶ Menu	

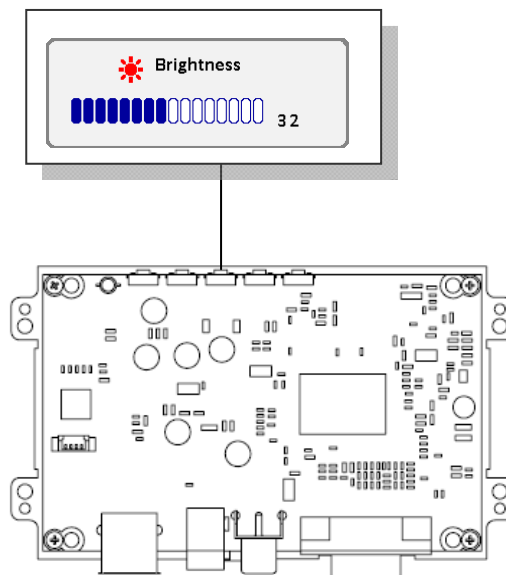

**Hot Key When OSD Menu is Off :**



## Information of Input Source and Functionality :



## Overview of Input Signals :

Indicator	Interface
	CVBS
	VGA

# 13. Dimension Information

## 13.1 Unit (FCOP0430)

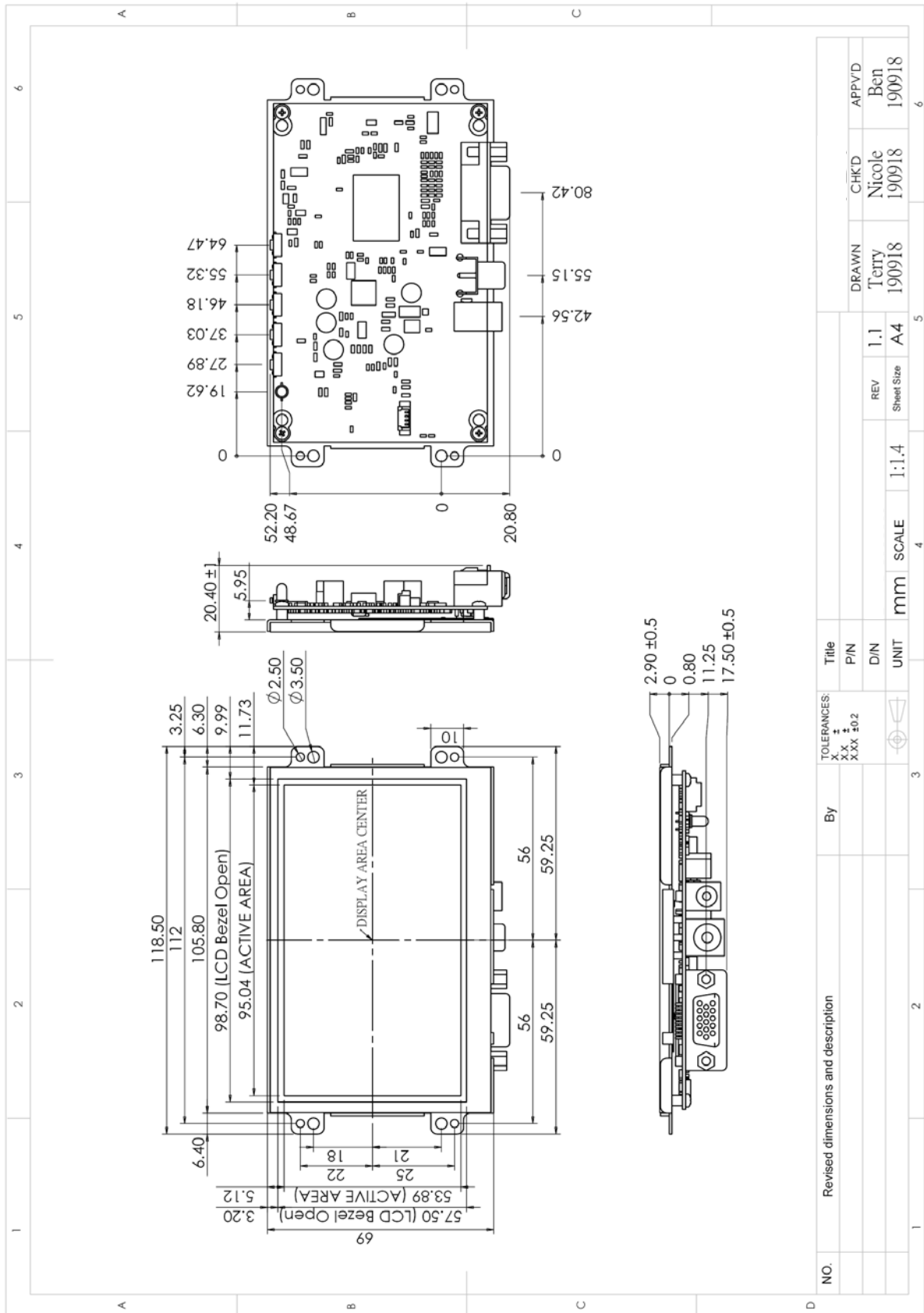

**13.2 Unit (FCOP0430-TR)**

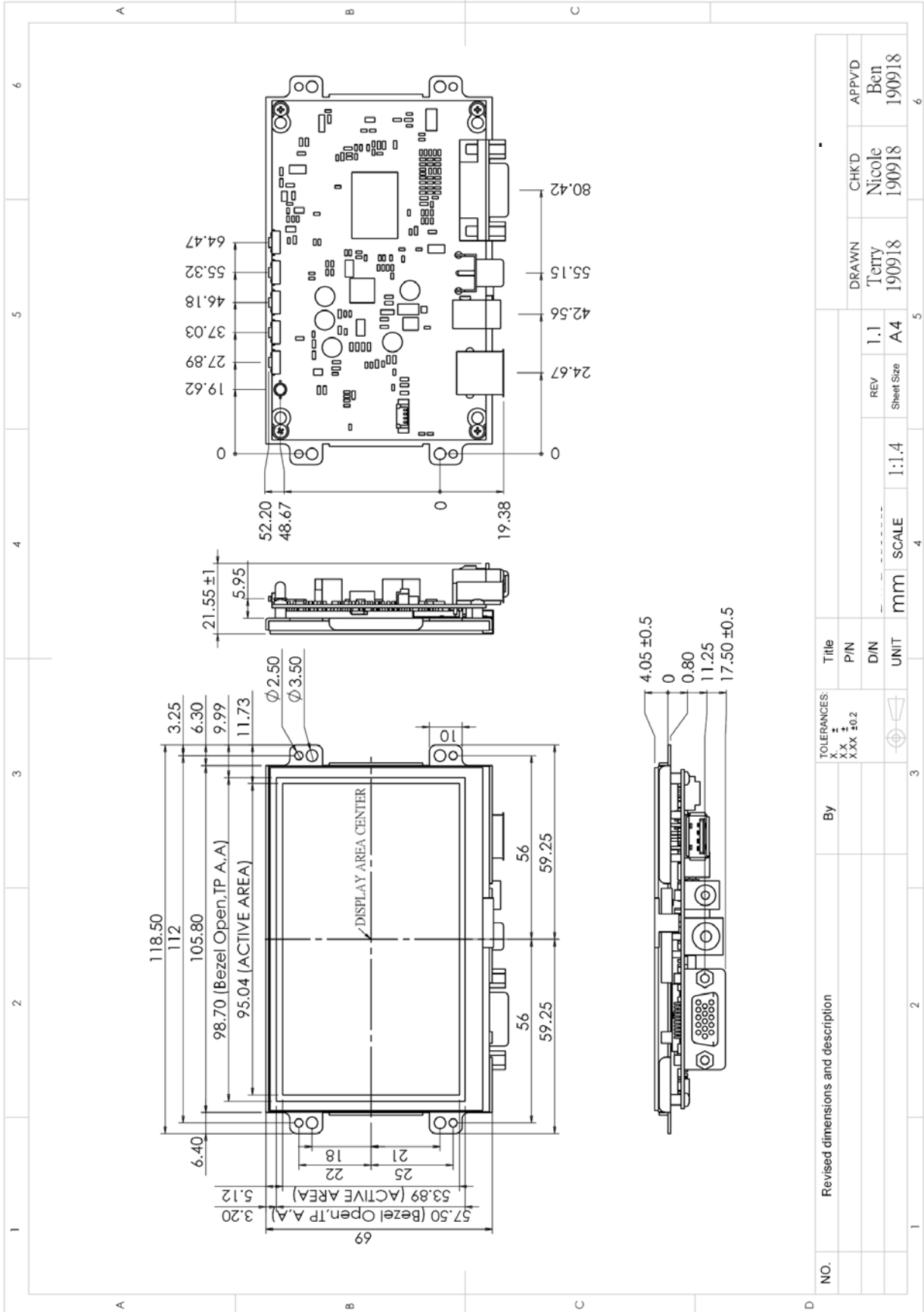



## 14. Appendix

### 14.1 TFT-LCD Mechanical Specifications

Parameter	Specifications	Unit
Screen Size	4.3 (diagonal)	Inch
Display Format	480 x (R.G.B) x 272	Dot
Active Area	95.04(W) × 53.856(H)	mm
Pixel Pitch	0.198(H) x 0.198(V)	mm
Pixel Arrangement	Stripe	
Outline Dimension	105.5(W) × 67.2(H) × 4.05(D)	mm
Surface Treatment	Anti-Glare	

### 14.2 TFT-LCD Optical Characteristics

Parameter	Symbol	Condition	Min	Typ	Max	Unit	Remark
Viewing Angle	Horizontal	Left	60	70	---	deg	
		Right	60	70	---	deg	
	Vertical	Top	40	50	---	deg	
		Bottom	60	70	---	deg	
Contrast Ratio	CR	$\Theta = 0^\circ$	400	500	---	---	
Response time	Rise Fall	Tr	---	10	20	ms	
		Tf	---	15	30	ms	
Uniformity	U	$\Theta = 0^\circ$	70	75	---	%	
Brightness without TP	L		400	500	---	cd/m <sup>2</sup>	
Brightness with RTP	L	$\Theta = 0^\circ$	350	400	---	cd/m <sup>2</sup>	
White Chromaticity	x	$\Theta = 0^\circ$	0.26	0.31	0.36		
	y	$\Theta = 0^\circ$	0.28	0.33	0.38		
LED Life Time		+25°C	20000	---	---	hours	Note

Note: The "LED Life Time" is defined as the module brightness decrease to 50% original.

14.3 Application Circuit

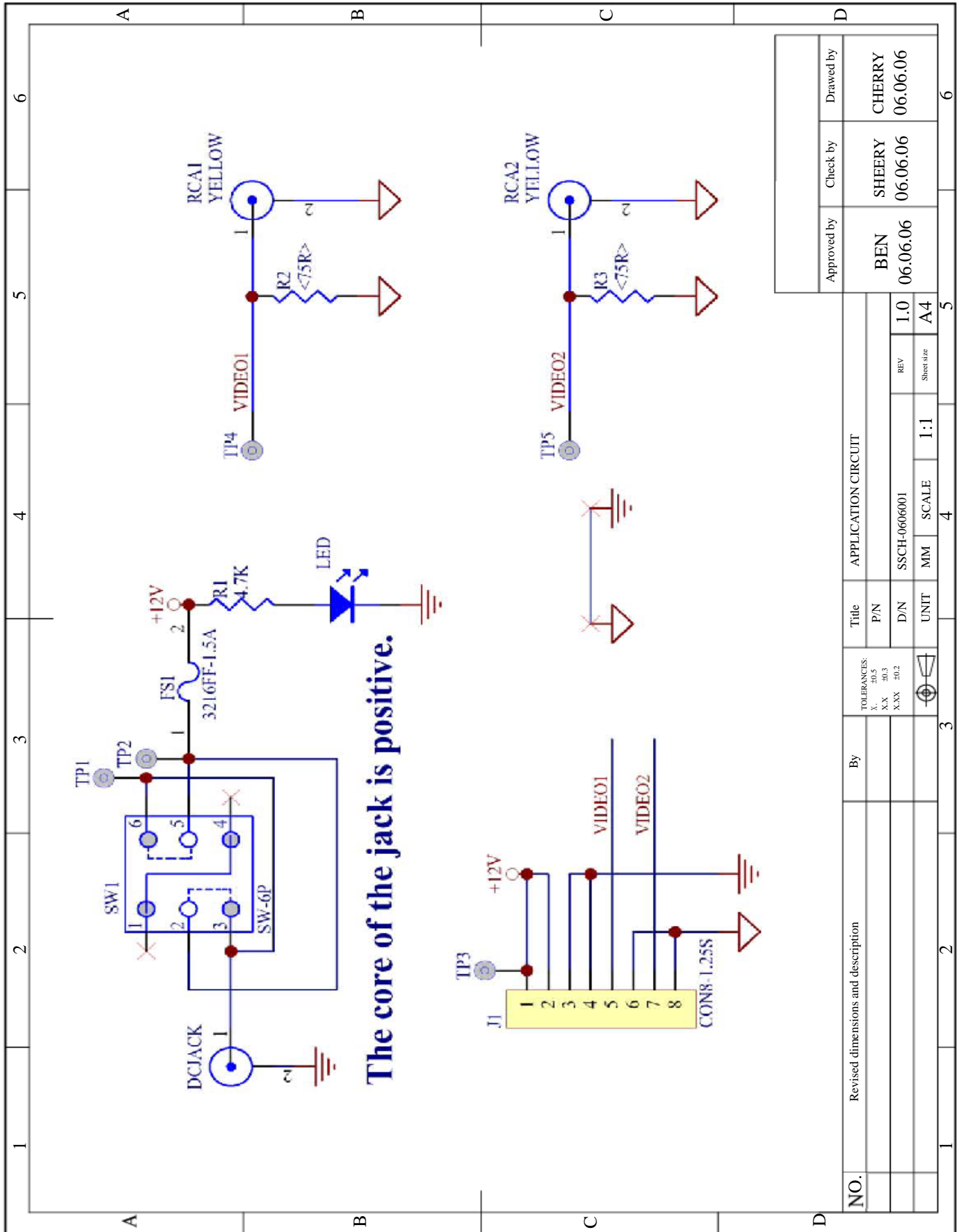

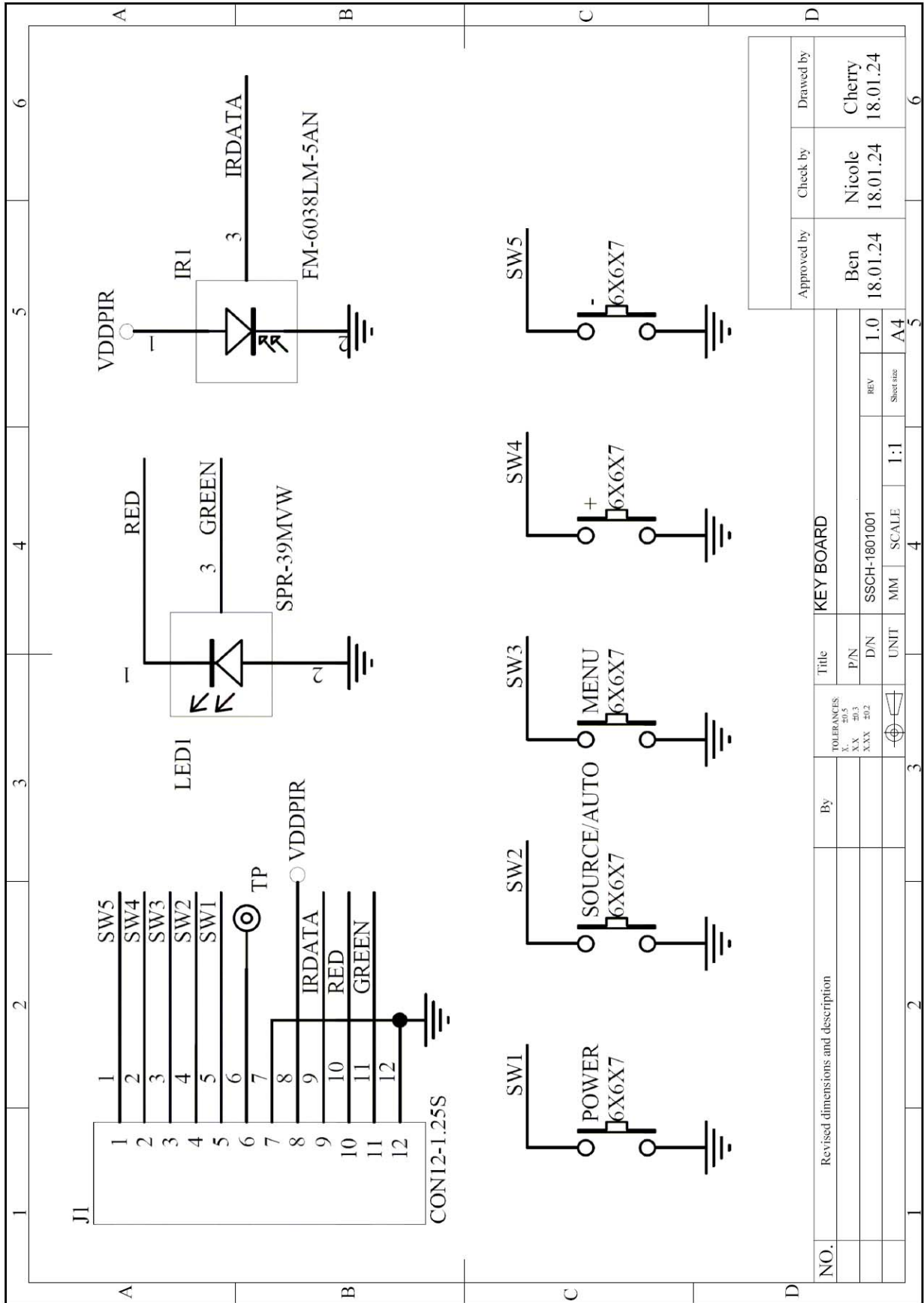

Approved by	Ben	18.01.24	Check by	Nicole	18.01.24	Drawn by	Cherry	18.01.24
-------------	-----	----------	----------	--------	----------	----------	--------	----------

NO.	Revised dimensions and description	By	Title		UNIT	SCALE	REV	Sheet size
			KEY BOARD					
			TOLERANCES:	P/N	D/N	MM	1:1	A4
			±.05					
			±.3					
			±.2					

14.5 (Option)

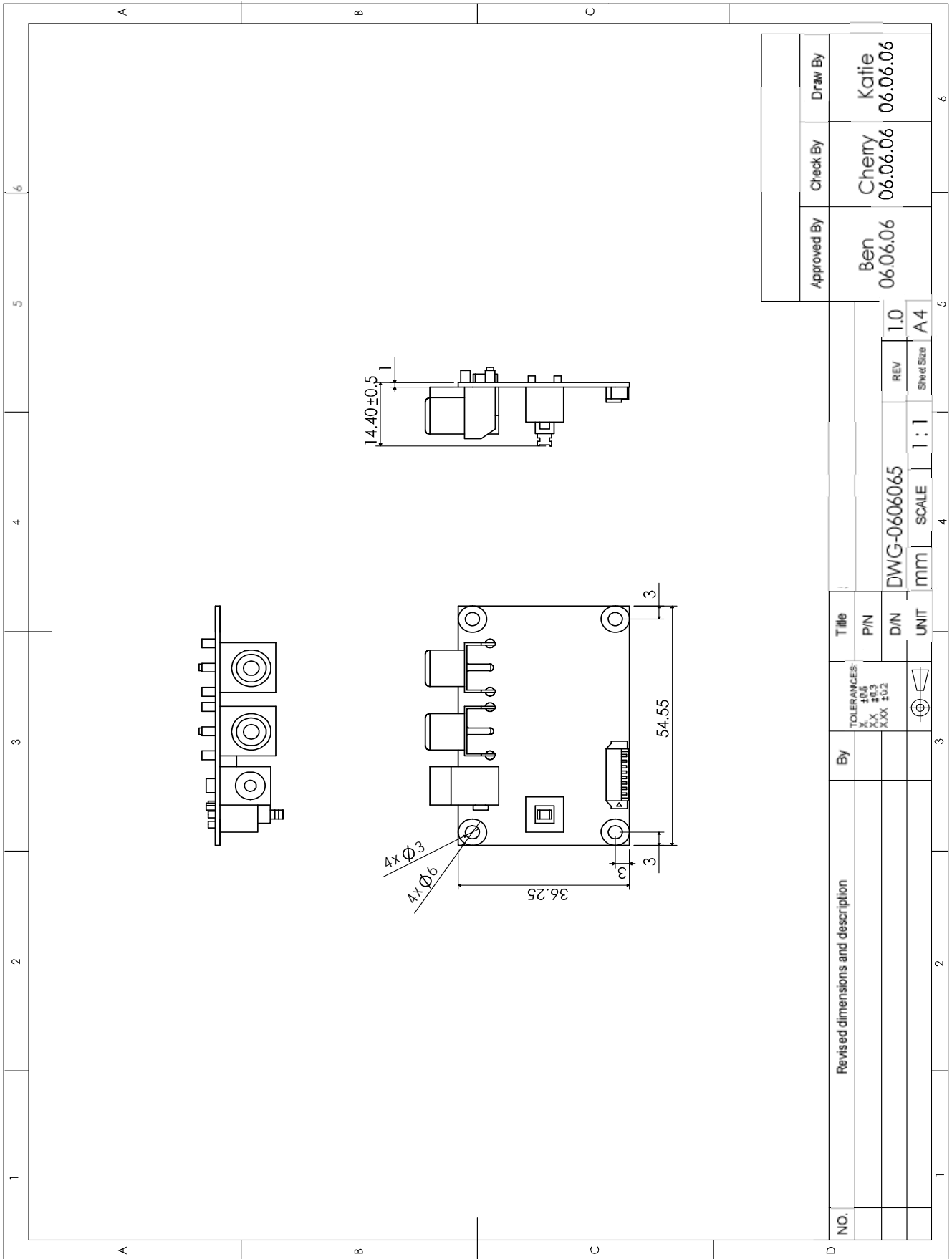

**14.6 (Option)**

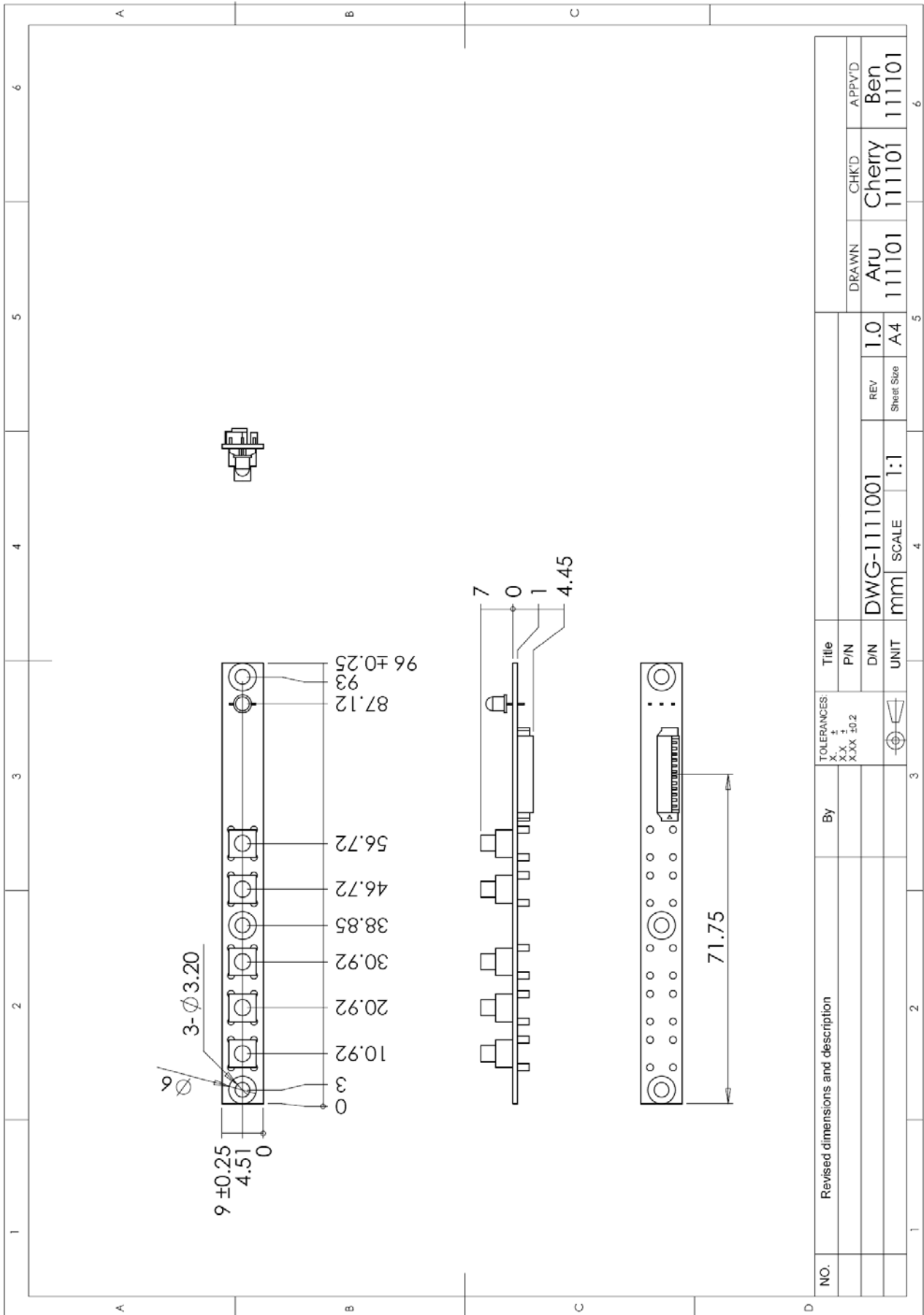

NO.	Revised dimensions and description	By	TOLERANCES: X.X ± X.XX ± X.XX ±0.2	Title	P/N	D/W	REV	SCALE	Sheet Size	DRAWN	CHK'D	APPV'D
										Arū	Cherry	Ben
				DWG-1111001			1.0	A4		111101	111101	111101
				UNIT			1:1					

**14.7 Cable: 8P-8P 1.25mm L: 100mm (Option)**

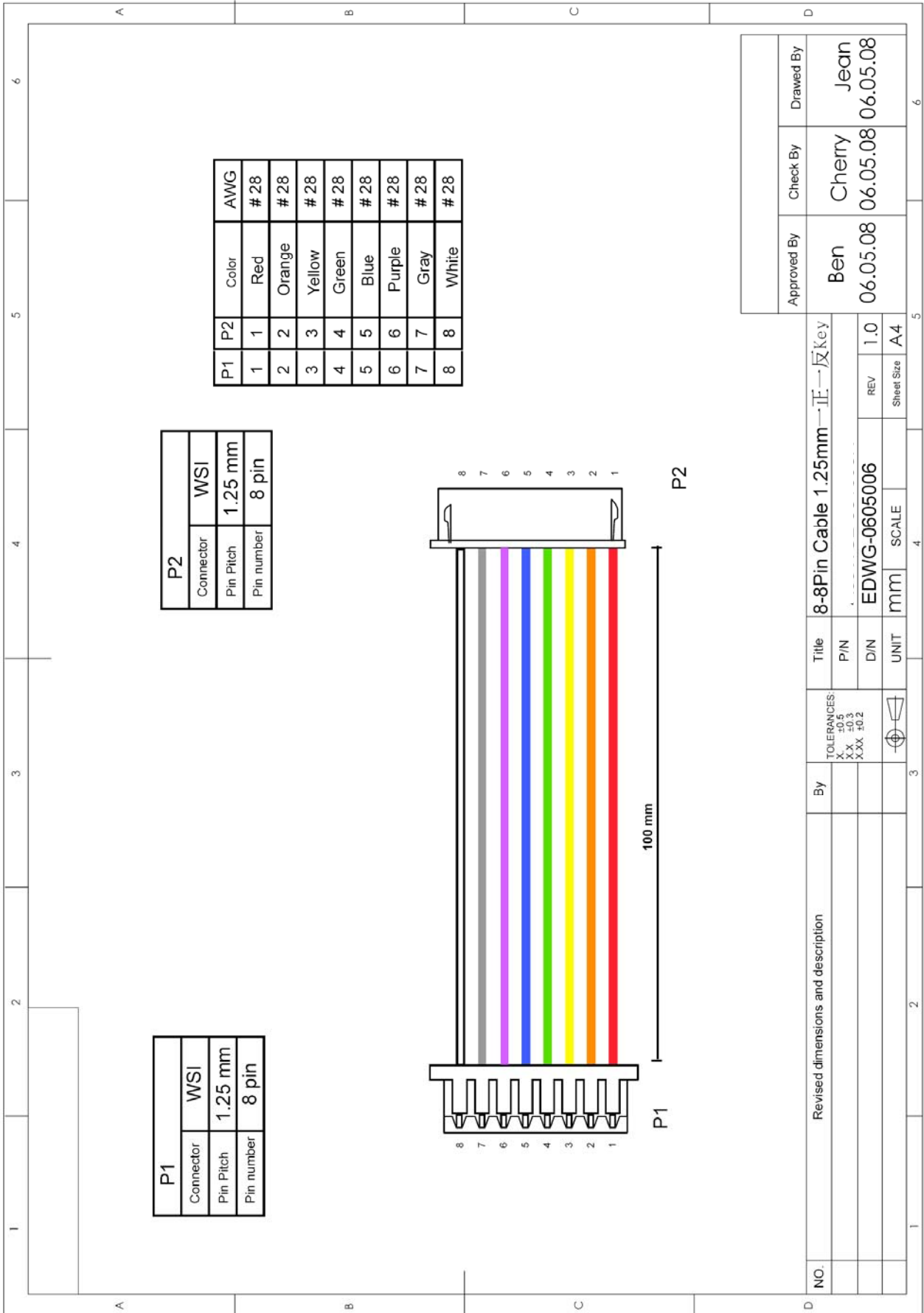

**14.8 Cable: 14P-14P 2.0mm L:110mm (Option)**

