

INDUSTRIAL CHASSIS/WALL MOUNT HEAVY DUTY METAL HOUSING

Front Water and Dust Proof IP65/NEMA 4 with IP65 Solid Back housing except I/O.
 19" LCD monitor, 1280 x 1024, 250 nits VGA + HDMI+DVI Input, Side OSD
 with 5 Wire Resistive Touch Screen and USB Controller
 (**USB B Type Female Connectors***)
 +12 VDC External power supply 100-240 VAC 50-60Hz included



Model: CCH1900IP-TR-B

Rugged IP65/NEMA4X Industrial touch screen monitor, iTech is the perfect solution for Dusty and Wet industrial environments. Heavy duty Metal housing with powder coating and affordable.

FEATURES:

- High Contrast color TFT LCD Monitor support resolution up to XGA (1280 x 1024)
- Power management system conforms to VESA DPMS and EPA Energy Star standards.
- Full consideration for touch screen installation and application.
- Universal Power adapter.
- Support DDC1 & DDC2B for Plug & Play compatibility.
- Advanced OSD control for picture quality adjustment.
- Detachable stand for wall-mounting application.
- Heavy duty Monitor with steel frame.
- IP65 Solid Back housing except I/O and VESA Mounting
- Custom design by request.

SPECIFICATIONS:

Display	Viewing Size Image	19"
	Active Display Area (mm)	377.5(H) x 302 (V)
	Pixel Pitch (mm)	0.294 (H) x 0.294(V)
	Resolution	1280 x 1024
	Contrast Ratio	1000 : 1 (typ.)
	Color	16.7M
	Brightness	250nits
	Viewing Angle	-85~85 (H) ; -80~80(V)
	Recommended Resolution	1280x 1024 @ 60Hz, 75Hz
Signal Connector	VGA+HDMI+DVI	

Power	Source	12 VDC External power supply 100-240 VAC 50-60Hz included
	Consumption	11.15W typical, normal operation
	Management	VESA DPMS Compliant
	Touch	5 Wire Resistive Touch Screen and USB Controller (**USB B Type Female Connectors***)
Optional	High Brightness	1000,1500
	Auto Dimming	YES
	POWER in	DC24V,DC 9V~36V
	Remote Control	YES
	IO	Video: VGA + DVI Power: 12 VDC External power supply 100-240 VAC 50-60Hz included Touchscreen: USB

*Specifications subject to change without notice, not responsible for typographical errors.



MECHANICAL DRAWING:

This is subject to change without Notice. Final Drawings Will be Provided for Approval after Order.

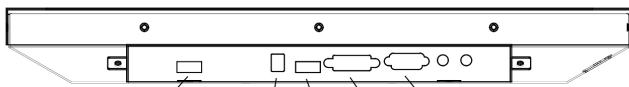
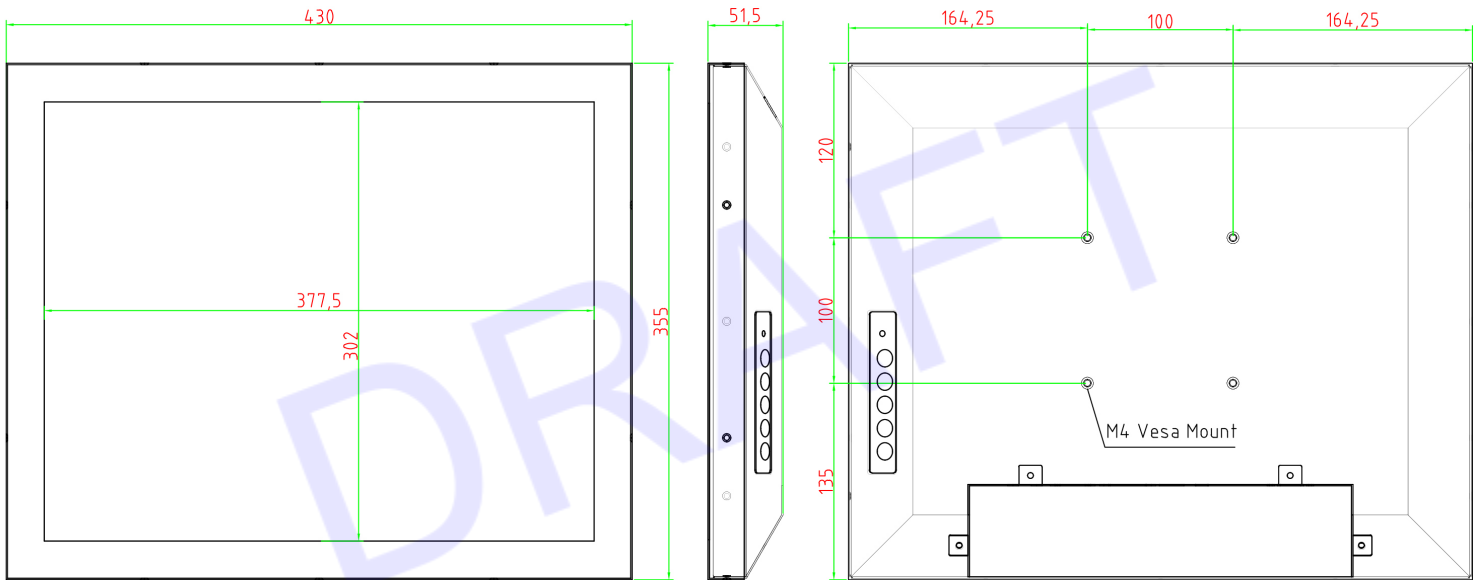

UNIT:mm

USB Type B touch connector DC12V HDMI DVI VGA

USB B Type Female Connectors

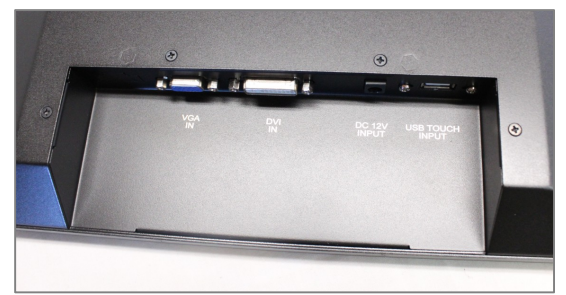
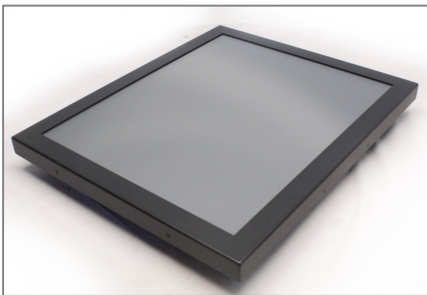

Drawing No.: CCH1900IP-TR-B-09282022-V1