

RUGGED MILITARY GRADE LCD KEYBOARD DRAWER

16 Ports 1U 17.3" Rackmount Rugged LCD Keyboard Drawer
1920 x1080, 300nits with Support combo interface
VGA-USB & VGA-PS/2

Model: AMilW1700SS16b



FEATURES

- Meet MIL-STD-810F/G standard
- 1U 17.3" LCD drawer
- Support 1920 x 1080 FHD resolution
- Short depth design suit for mobile rack and limited space 46cm chassis depth, mounting range is 45~65cm
- Support combo interface, VGA-USB & VGA-PS/2
- Sealed IP65 silicone keyboard and trackball with backlight
- MIL connector for power input
- Self-locking and auto release rails for ultra convenience
- Port selection via push buttons or On-Screen-Display (OSD).
- Dedicated daisy chain port to expand up to 240 servers.
- Included 16-ports RGB DB-15 KVM
- Included 16 x 1.8meter 2-in-1 KVM Cable-USB&VGA Part no AB-6

OPTION

- DC 9~36V power input
- High brightness LCD panel, up to 1000 nits
- Front AR or EMC glass protect screen

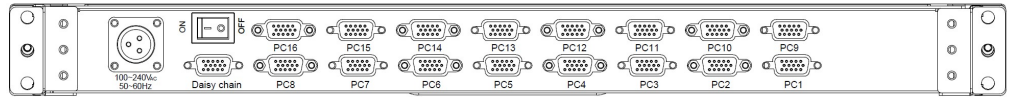

Rear of AMilW1700SS16b

SPECIFICATIONS

Direct no. of Computers	16	
Maximum no. of Computers	232(Daisy Chain)	
LCD	Size	17.3"
	Backlight	LED
	Resolution	1920*1080 Full HD (support resolution up to 1920x1200)
	Max.color	262K
	Luminance	300cd/m2
	View Angel (H/V)	140 / 120
	Contrast Ratio	650 : 1
Port Selection	Push Button, Hotkey	
USB Local Console	N/A	
KB/Mouse Emulation	USB & PS2	
Rack Depth	450 mm to 650mm (rack cabinet front rails to rear rails)	
Power	100-240V AC 50/60Hz via 3 pins lock connector	
Environment (MIL-STD-810G)	Operation temp: 0 to 50°C	(MIL-STD-810, Method 501.5 & 502.5)
	Storage temp: -20 to 60°C	(MIL-STD-810, Method 501.5 & 502.5)
	Humidity: 10% - 90%, non-condensing	(MIL-STD-810, Method 507.5)
	Shock/Vibration: Procedure VI, 50G @ 11ms	(MIL-STD-810, Method 516.6)
	Altitude: 10,000 ft Operational, 30,000 ft Storage	(MIL-STD-810, Method 500.5)
Physical Dimensions / Net Weights	482x43x460mm (WxHxD) /14KG	
Packing Dimensions / Gross weights	605x168x700mm (WxHxD) /17KG	

Accessories

1 x 1.8 Power Cord with lock connector

Option Relate Item

AB-6	1.8meter 2-in-1 KVM Cable-USB&VGA	AD-6	1.8meter 3-in-1 KVM Cable-PS/2&VGA
AB-10	3.0meter 2-in-1 KVM Cable-USB&VGA	AD-10	3.0meter 3-in-1 KVM Cable-PS/2&VGA
AB-15	5.0meter 2-in-1 KVM Cable-USB&VGA	AD-15	5.0meter 3-in-1 KVM Cable-PS/2&VGA

*Specifications subject to change without notice, not responsible for typographical errors.

MECHANICAL DRAWINGS

This is subject to change without Notice. Final Drawings Will be Provided for Approval after Order.

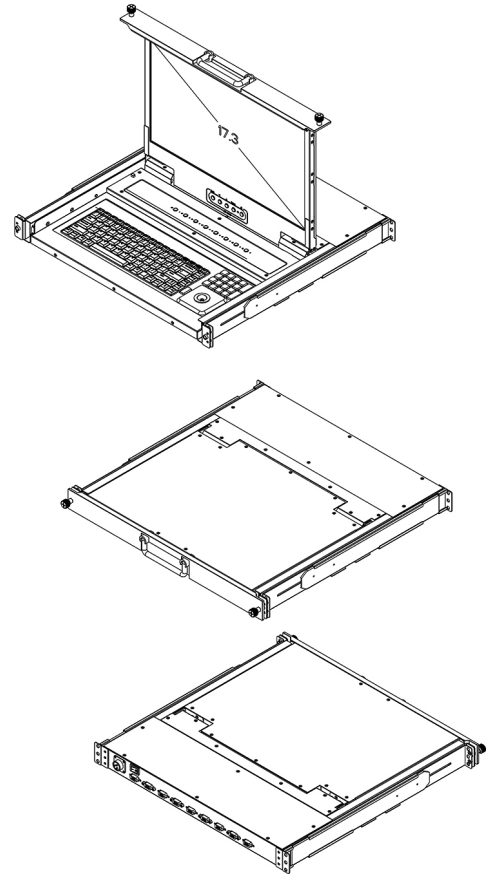
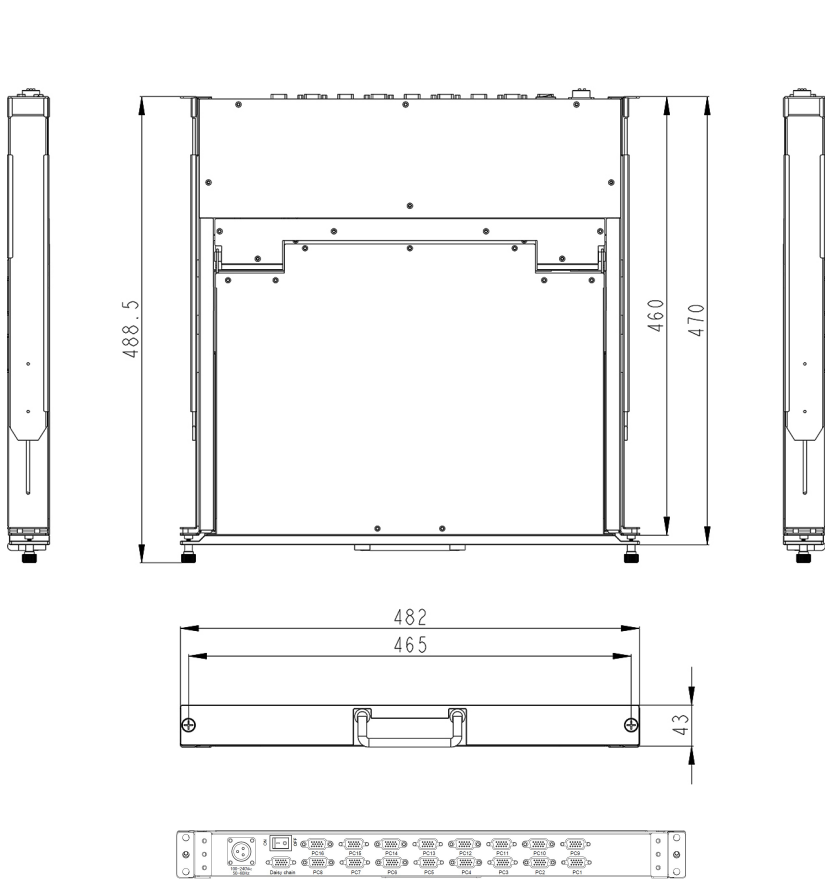

Drawing no.: AMiW1700SS16b-07132023-V1