

RUGGED MILITARY GRADE LCD KEYBOARD DRAWER



1U 17.3" Rackmount Rugged LCD Keyboard drawer 1920 x1080, Support up to 1920 x 1200, 400nits, Sealed 104-keys IP65 silicone USB only keyboard and touchpad with backlight, Front EMC glass, with 8 ports DB-15 combo KVM switch + Internal power supply with universal / Auto-Sensing, 100-240V AC 50/60Hz via 3 pins lock connector

482x42x600mm (WxHxD) /13.5KG

Operating temp. 0~70C

Storage temp -30~75C

Model: AMil-W1730-S8e



FEATURES

- Meets MIL-STD-810F/G standard
- 1U 17.3" LCD Console Drawer, support 1920x1080 resolution
- Support up to 1920 x 1200 resolution
- Built-in 8 port combo KVM switch, support VGA-USB & VGA-PS/2.
- Sealed 104-keys IP65 silicone keyboard and touchpad with backlight
- MIL connector for power input
- Self-locking and auto release rails for ultra convenience
- Port selection via push buttons or On-Screen-Display (OSD)

OPTIONAL REMOTE IP ACCESS

- An expansion slot allows you to add an optional KVM over IP module to enable remote access to your servers.
- Gain BIOS level access to your servers for system maintenance, support or failure recovery via secure SSL authentication and encryption.

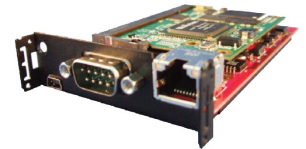

OPTION

- DC 9~36V power input
- High brightness LCD panel, up to 1000 nits
- Front AR or EMC glass protect screen

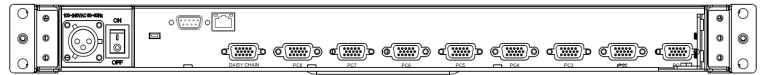

Rear of AMil-W1730-S8e

SPECIFICATIONS

Direct no. of Computers	8	
KVM Connectors	232 (Daisy Chain)	
LCD	Size	17.3"
	Backlight	LED
	Resolution	1920*1080 Full HD (support resolution up to 1920x1200)
	Max.color	16.7M
	Luminance	400cd/m2
	View Angel (H/V)	160 / 140
	Contrast Ratio	600 : 1
Port Selection	Push Button, Hotkey	
Expansion Slot	Yes, option for Remote IP Access	
KB/Mouse Emulation	USB & PS2	
Rack Depth	600mm to 1000mm (rack cabinet front rails to rear rails)	
Power	100-240V AC 50/60Hz via 3 pins lock connector	
Environment (MIL-STD-810G)	Operation temp: 0 to 70°C	(MIL-STD-810, Method 501.5 & 502.5)
	Storage temp: -30 to 75°C	(MIL-STD-810, Method 501.5 & 502.5)
	Humidity: 5% - 95%, non-condensing	(MIL-STD-810, Method 507.5)
	Shock/Vibration: Procedure VI, 50G @ 11ms	(MIL-STD-810, Method 516.6)
	Altitude: 10,000 ft Operational, 30,000 ft Storage	(MIL-STD-810, Method 500.5)
Physical Dimensions / Net Weights	482x42x600mm (WxHxD) /13KG	
Packing Dimensions / Gross weights	720x160x860mm(WxHxD) /19KG	

Accessories

1 x 1.8 Power Cord with lock connector

Option Related Items

AB-6	1.8meter 2-in-1 KVM Cable-USB&VGA	AD-6	1.8meter 3-in-1 KVM Cable-PS/2&VGA
AB-10	3.0meter 2-in-1 KVM Cable-USB&VGA	AD-10	3.0meter 3-in-1 KVM Cable-PS/2&VGA
AB-15	5.0meter 2-in-1 KVM Cable-USB&VGA	AD-15	5.0meter 3-in-1 KVM Cable-PS/2&VGA

**Specifications subject to change without notice, not responsible for typographical errors.*

MECHANICAL DRAWINGS

This is subject to change without Notice. Final Drawings Will be Provided for Approval after Order.

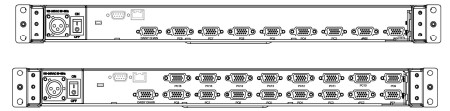
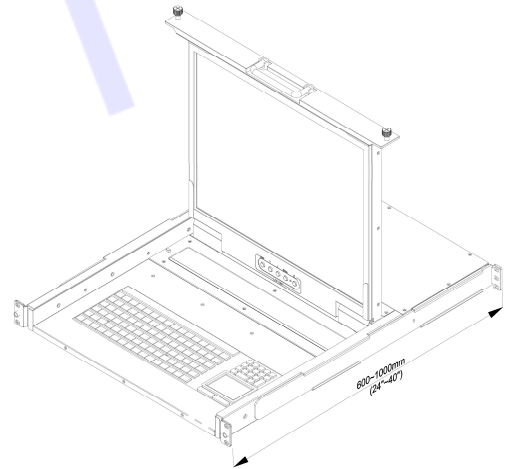
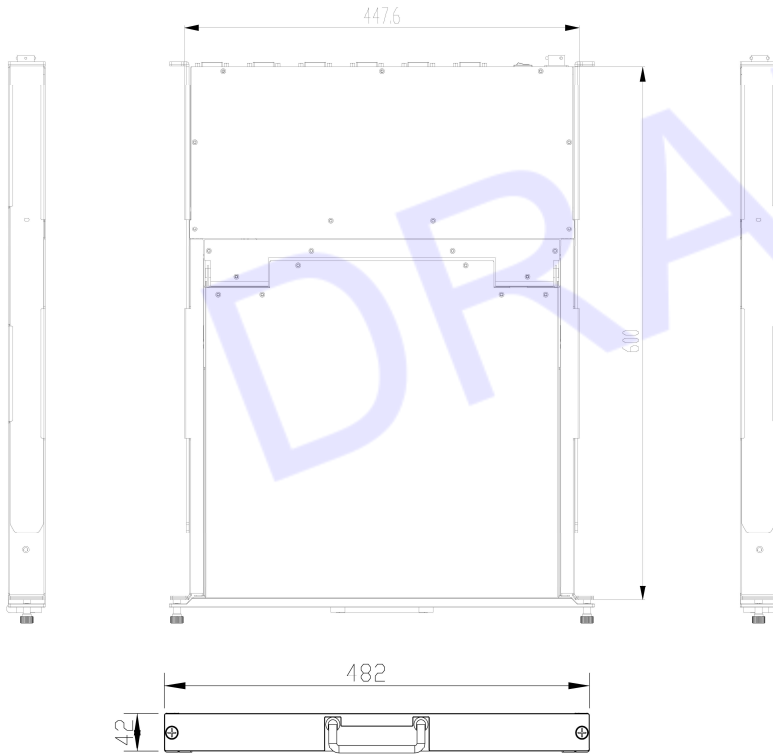
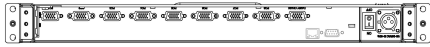

Drawing no.: AMil-W1730-S8e -07202022-V1