

RUGGED MILITARY GRADE LCD KEYBOARD DRAWER



1U 17.3" Rackmount Rugged LCD Keyboard drawer 1920 x1080, 300nits, Sealed 104-keys IP65 silicone USB only keyboard and touchpad with backlight, Front EMC glass, with 16 ports DB-15 combo KVM switch + DC 9~36V, the power supply is internal as well. We will provide + - wire power cable.

482x42x600mm (WxHxD) /13.5KG
 Operating temp: 0 ~ 50C
 Storage temp: -20 ~ 60C

Model: AMil-W1730-S16e-DC



FEATURES

- Meets MIL-STD-810F/G standard
- 1U 17.3" LCD Console Drawer, support 1920x1080 resolution
- Support up to 1920 x 1200 resolution
- Built-in 16 port combo KVM switch, support VGA-USB & VGA-PS/2.
- Sealed 104-keys IP65 silicone keyboard and touchpad with backlight
- MIL connector for power input with internal 9~36VDC power
- Self-locking and auto release rails for ultra convenience
- Port selection via push buttons or On-Screen-Display (OSD)

OPTIONAL REMOTE IP ACCESS

- An expansion slot allows you to add an optional KVM over IP module to enable remote access to your servers.
- Gain BIOS level access to your servers for system maintenance, support or failure recovery via secure SSL authentication and encryption.

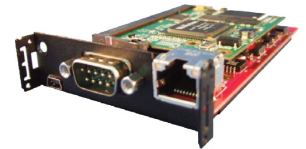

OPTION

- High brightness LCD panel, up to 1000 nits
- Front AR or EMC glass protect screen

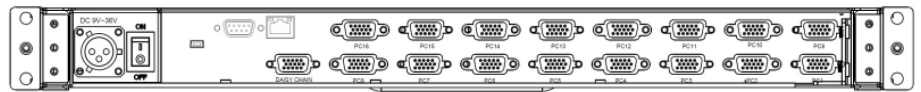

Rear of AMil-W1730-S16e-DC

SPECIFICATIONS

Direct no. of Computers	16	
KVM Connectors	240 (Daisy Chain)	
LCD	Size	17.3"
	Backlight	LED
	Resolution	1920*1080 Full HD (support resolution up to 1920x1200)
	Max.color	262K
	Luminance	300cd/m2
	View Angel (H/V)	140 / 120
	Contrast Ratio	650 : 1
Port Selection	Push Button, Hotkey	
Expansion Slot	Yes, option for Remote IP Access	
KB/Mouse Emulation	USB & PS2	
Rack Depth	600mm to 1000mm (rack cabinet front rails to rear rails)	
Power	9~36V DC via 3 pins lock connector	
Environment (MIL-STD-810G)	Operation temp: 0 to 50°C	(MIL-STD-810, Method 501.5 & 502.5)
	Storage temp: -20 to 60°C	(MIL-STD-810, Method 501.5 & 502.5)
	Humidity: 5% - 95%, non-condensing	(MIL-STD-810, Method 507.5)
	Shock/Vibration: Procedure VI, 50G @ 11ms	(MIL-STD-810, Method 516.6)
	Altitude: 10,000 ft Operational, 30,000 ft Storage	(MIL-STD-810, Method 500.5)
Physical Dimensions / Net Weights	482x42x600mm (WxHxD) /13KG	
Packing Dimensions / Gross weights	720x160x860mm(WxHxD) /19KG	

Accessories

1 x 1.8 Power Cord with lock connector

Option Related Items

AB-6	1.8meter 2-in-1 KVM Cable-USB&VGA	AD-6	1.8meter 3-in-1 KVM Cable-PS/2&VGA
AB-10	3.0meter 2-in-1 KVM Cable-USB&VGA	AD-10	3.0meter 3-in-1 KVM Cable-PS/2&VGA
AB-15	5.0meter 2-in-1 KVM Cable-USB&VGA	AD-15	5.0meter 3-in-1 KVM Cable-PS/2&VGA

**Specifications subject to change without notice, not responsible for typographical errors.*

MECHANICAL DRAWINGS

This is subject to change without Notice. Final Drawings Will be Provided for Approval after Order.

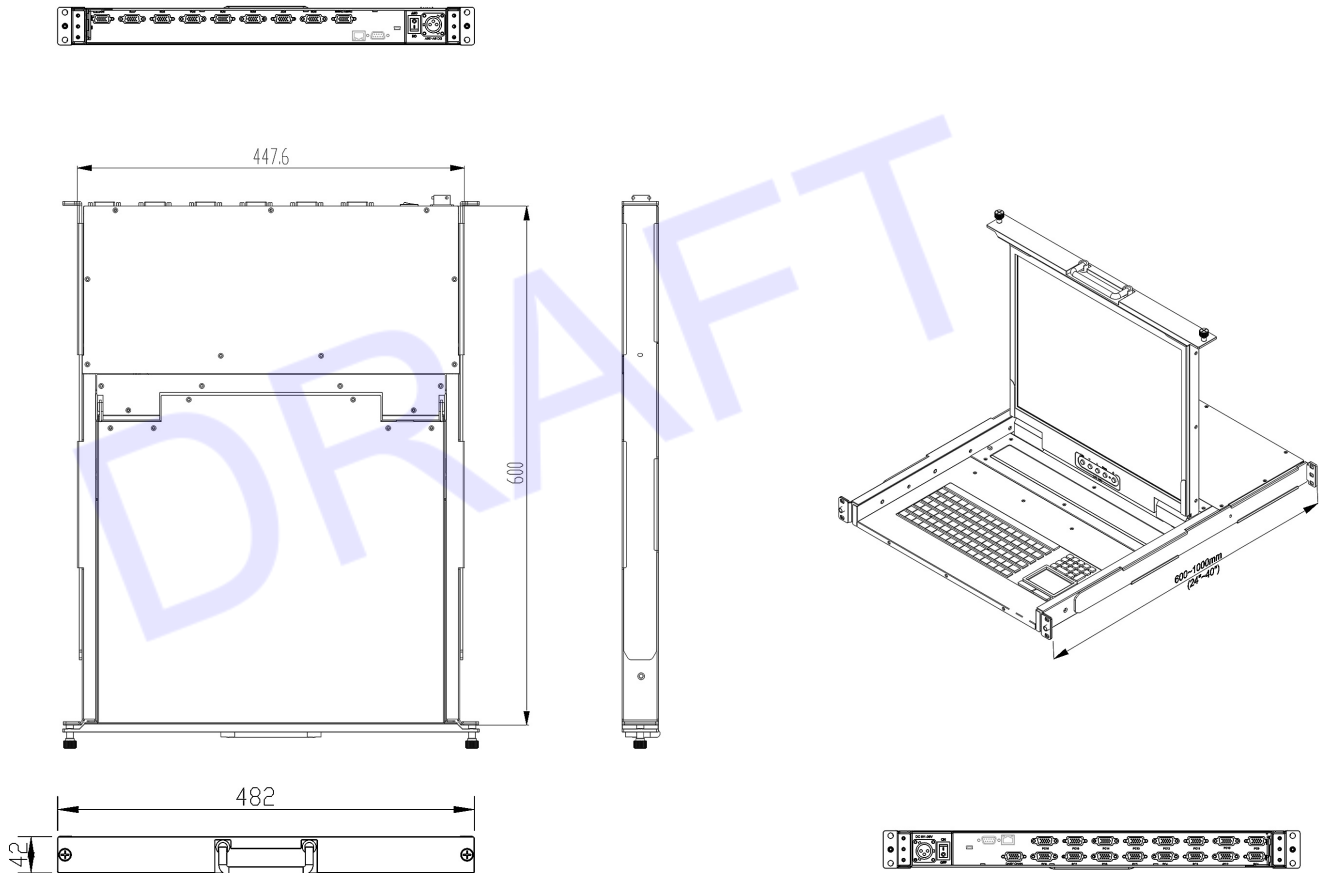

Drawing no.: AMil-W1730-S16e-DC-02022024-V1

MODEL: AB-6 /AB-10 / AB-15

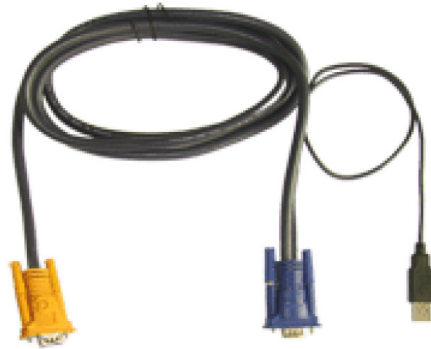

- ① 15Pin D-sub Male (to KVM)
- ② USB x 1 type A Male (to USB port)
- ③ 15Pin D-sub Male (to VGA port)

FEATURES

- 1.8 meters, 3 meters, 5 meters options available
- KVM cable designed for 19" rack mounting Combo (PS2 & USB) KVM Switch series