

Military Rugged Rackmount LCD Drawer

1U 19" Rackmount Rugged LCD Keyboard drawer 1280 x 1024, 400nits, Durable 104-key waterproof keyboard, Front EMC glass, 100-240VAC 50-60Hz input, Short Depth 600mm Deep extend to 1000mm, No Speaker

Video input: VGA+DVI
 Operation temp: -20 to 70C
 Storage temp: -30 to 80C
 Humidity: 5% - 95%, non-condensing
 Shock: 10G acceleration (11ms duration)
 Vibration: 17 to 500Hz 1G PTP
 MS3106R10SL-3S (female connector, solder with power cord)
 MS3102R10SL-3P (male connector, stable on the rear of KVM)



Model: AMil-1900-EMI-AM1-AC

FEATURES

- Meet MIL-STD-810F/G standard
- 1U 19" LCD Console Drawer, wide operation temperature support 1280 x 1024 resolution
- DVI & VGA Port
- Front 1x USB, Rear 1 x USB 2.0 Type A, Sharing USB peripheral
- Device for computer (ex, flash disk, hard driver, KB/Mouse)
- Sealed 104-keys IP65 silicone keyboard and touchpad with backlight
- MIL connector for power input
- Support USB 2.0 Keyboard & Mouse

Option

- DC 9~36V power input
- High brightness LCD panel, up to 1000 nits
- Front AR or EMC glass protect screen
- Touch screen

AC input:

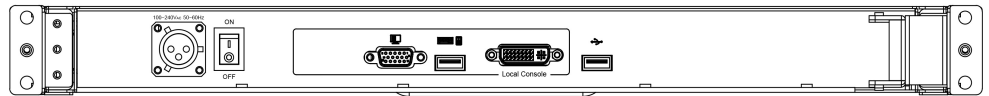

REAR VIEW

SPECIFICATIONS

Direct no. of Computers		1
LCD	Size	19"
	Backlight	LED
	Resolution	1280 x 1024
	Max.color	16.7M
	Luminance	400cd/m2
	View Angel (H/V)	170 / 160
	Contrast Ratio	1000 : 1
USB HUB	Front 1x USB, Rear 1 x USB 2.0 Type A, Sharing USB peripheral	
Touch Screen	Yes, for option	
KB/Mouse Emulation	USB	
Rack Depth	600mm to 1000mm (rack cabinet front rails to rear rails)	
Power	100-240V AC 50/60Hz via 3 pins lock connector	
Environment (MIL-STD-810G)	Operation temp: -20 to 70°C	(MIL-STD-810, Method 501.5 & 502.5)
	Storage temp: -30 to 80°C	(MIL-STD-810, Method 501.5 & 502.5)
	Humidity: 5% - 95%, non-condensing	(MIL-STD-810, Method 507.5)
	Shock: 10G acceleration (11ms duration)	(MIL-STD-810, Method 516.6)
	Vibration: 17 to 500Hz 1G PTP	(MIL-STD-810, Method 500.5)
Altitude: 10,000 ft Operational, 30,000 ft Storage	(MIL-STD-810, Method 500.5)	
Physical Dimensions / Net Weights	482x42x600mm (WxHxD) /13KG	
Packing Dimensions / Gross weights	720x160x860mm(WxHxD) /19KG	
Accessories		
1 x 1.8 Power Cord with lock connector, 1.8 meter DVI-D Cable, 1.8 meter VGA Cable , 1.8 meter USB Cable (each one)		

**Specifications subject to change without notice, not responsible for typographical errors.*

MECHANICAL DRAWINGS

This is subject to change without Notice. Final Drawings Will be Provided for Approval after Order.

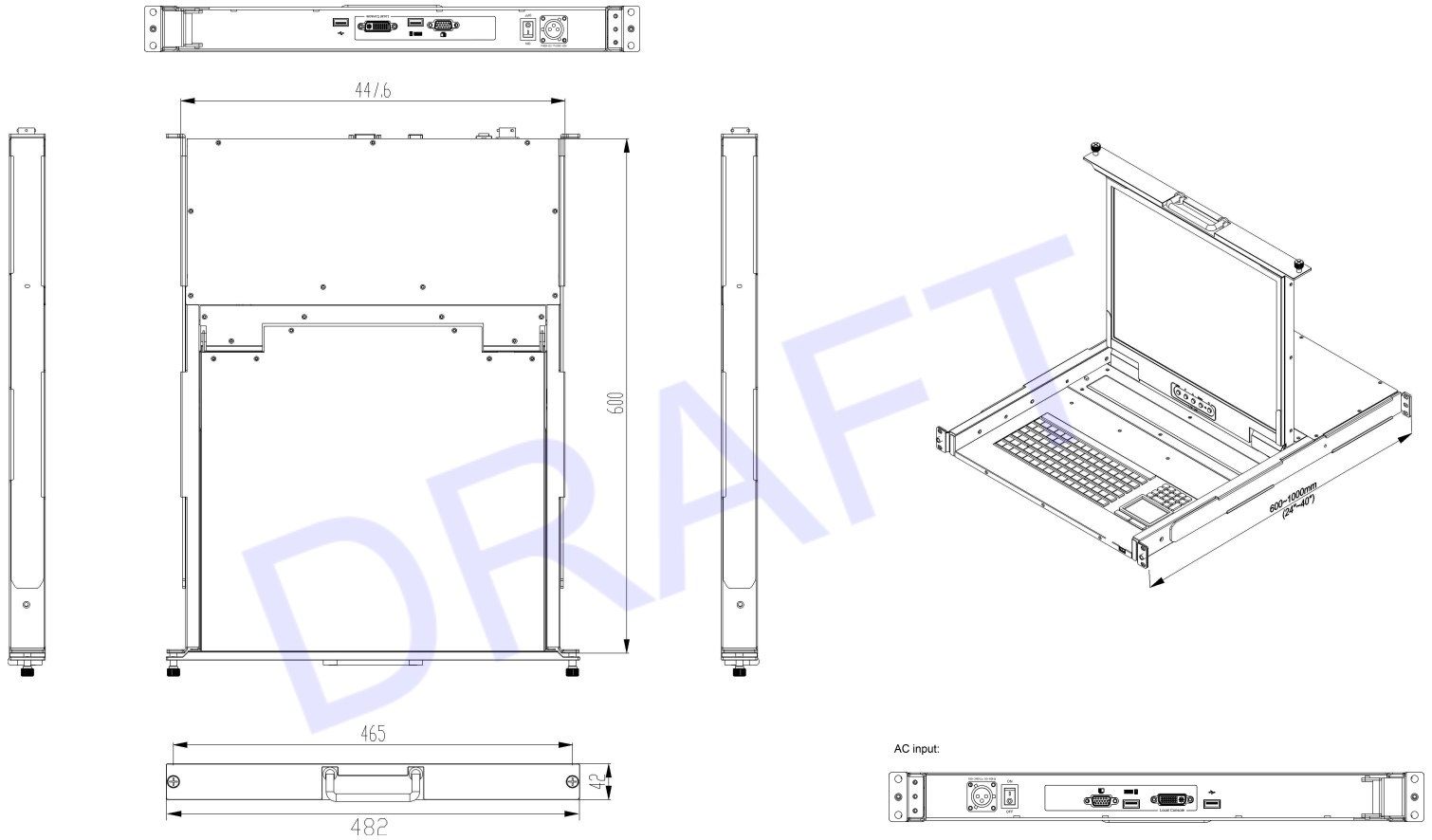

Drawing no.: AMil-1900-EMI-AM1-AC-06162022-V1

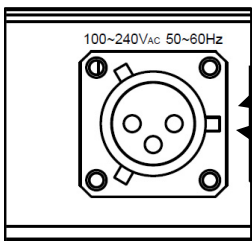

MS3106R10SL-3S (female connector, solder with power cord)

MS3102R10SL-3P (male connector, stable on the rear of KVM)