



19" SXGA HB1000nits IP65 Intel Core i5-6300U 2.4GHz, fan less panel PC, 16GB DDR4 memory, 1 x 256GB 2.5" MLC SSD, 1 x 64GB mSATA MLC SSD, Projected capacitive touch, DC9~36V power input, 316 stainless steel enclosure, support VESA Mount, WT-20~60

MODEL: WPC1900i7EX-C1D2-H1

FEATURES:

- 19-inch TFT-LCD Display
- Intel 6th Generation Core i5 Processor
- Constructed with SUS 316 Stainless Steel
- Achieves Total IP66 Grade with M12 Waterproof Connector
- Offers a Variety of IO Applications
- Supports Wide Range DC 9~36V Power Input
- Compatible with Panel Mount & VESA Mount
- Features Projected Capacitive Touch Support
- Boasts a Full Flat Bezel and Fanless Design
- ATEX/IECEx Zone2, Zone22 and C1D2/C2D2/C3 Certified
- Windows 10 IoT Enterprise 2021 LTSC Value PKEA
- Accessories : 1x M12 for 2x USB2.0 Cable, 2x M12 LAN cable, 1x M12 COM Cable, 1x VGA Cable, 1x 3pin power input cable (w/o Adapter)
- Power Adapter
- Power Cable



SPECIFICATION:

SYSTEM	
CPU	Onboard 6th Gen Intel Core i3/i5 processor
System Chipset	SoC
Memory	1 x 260-pin SO-DIMM up to 16GB DDR4 2133MHz
I/O PORT	
USB	1 x M12 8-pin for 2 x USB 2.0 with waterproof cover and chain
Serial / Parallel	1 x M12 8-pin for COM1, RS-232/422/485, default RS-232, with waterproof cover and chain
LAN	2 x M12 8-pin for LAN with waterproof cover and chain
Power	1 x M12 3-pin for DC power connector with waterproof cover and chain
Graph	1 x M12 8-pin for VGA with waterproof cover and chain
STORAGE SPACE	
HDD	1 x 2.5" HDD or SSD space 1 x mSATA space
Movable Device	1 x Internal SD Card
EXPANSION	
Expansion Slot	1 x Mini-PCIe (full size)
DISPLAY	
Display Type	19" TFT-LCD
Max. Resolution	1280x1024
Max. Color	16.7M
Luminance (cd/m ²)	1000
View Angle	170(H) /160(V)
Contrast	1000:1
Backlight Lifetime	70,000 hrs
TOUCHSCREEN	
Type	Projected Capacitive Touch
Interface	USB
Light Transmission(%)	90%
POWER	
Power Input	DC 9~36V
Power Consumption	24W

MECHANICAL	
Construction	316 stainless steel chassis
Mounting	VESA mount 100 x 100, Panel mount (option)
Dimensions (WxHxD)	470 x 388.6 x 75 mm
IP Rating	Total IP66
Net Weight	13.2 / 13.4 kg
ENVIRONMENTAL	
Operating Temperature	-20~60°C
Storage Temperature	-30~70°C
Storage Humidity	10 to 95% @ 40°C, non-condensing
Certificate	CE / FCC Class A ATEX / IECEx Zone2 Ex ec ic IIC T4 Gc ATEX / IECEx Zone22 Ex tc IIIC T135°C Dc Class I, Division2, Group A,B,C,D,T4 Class II, Division2, Group F,G, T135°C Class III ANSI/ISA 12.12-01-2013 CSA Std., C22 No213-1987
OPERATING SYSTEM SUPPORT	
Windows embedded 7, Windows embedded 8.1, Windows 10 IoT ENT LTSB	

**Specifications subject to change without notice, not responsible for typographical errors.*

DIMENSION:

This is subject to change without Notice. Final Drawings Will be Provided for Approval after Order.

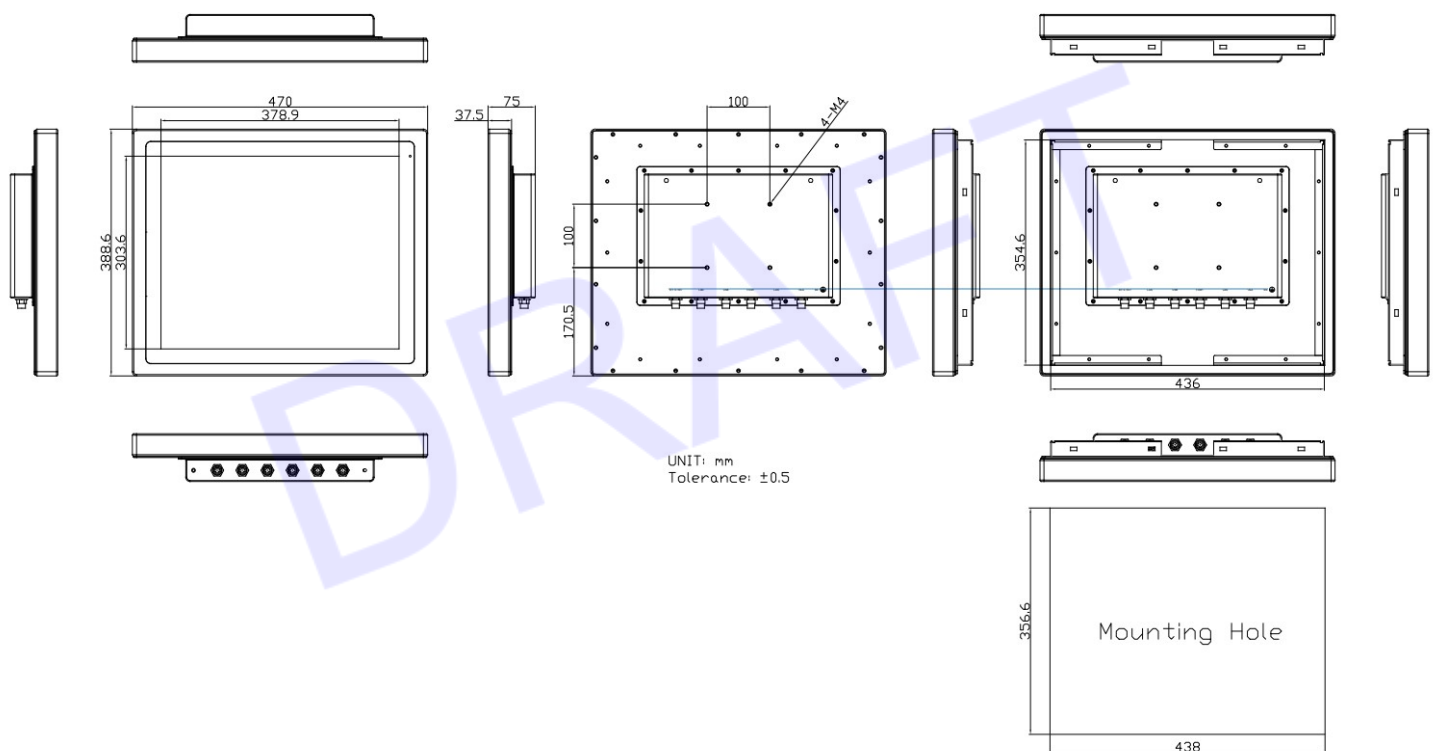

Drawing No.: WPC1900i7EX-C1D2-H1-01022024-V1