

7" WVGA fanless HMI barebone with Intel Pentium N4200 (1.1 GHz) CPU, 4GB DDR3L RAM, Projected Capacitive touch, 9~36VDC input with adapter, Aluminum chassis. UL Certificated

**MODEL: APCW07N4-UL-P-V1**

## FEATURES:

- 7" Industrial Compact Size Panel PC
- Flat front panel touch screen
- IP66 compliant front panel
- Intel Apollo Lake N4200/ N3350 (option)
- On Board 4GB/ 8GB DDR3L 1600MHz
- Optional projected capacitive touchscreen support 7H anti-scratch surface
- DC 9~36V wide-ranging power input
- High Brightness 1,000 nits for option
- Storage MO-297 SATA (MLC): 64G/MLC/SATA3/mSATA/MO-300A/TRANSCEND/TS64GMSA372M
- O/S: WIN10 IoT Ent LTSB 2016 MultiLang OEI ENTRY EPKEA (ESD) (6EU-00036)



## SPECIFICATION:

SYSTEM	
CPU	Onboard Intel Apollo Lake N4200 (4 Core, 1.1GHz) / N3350 (2 Core, 1.1GHz) (option)
System Chipset	SoC
Memory	Onboard 4GB/ 8GB (option) DDR3L 1600MHz
External IO Port	
USB	2 x USB 3.0 type A
Serial / Parallel	1 x DB-9 RS-232/422/485, COM1 (Default RS-232) 1 x RS-232 DB-9, COM2
LAN	2 x GbE LAN RJ-45
Audio	1 x Audio Line Out
Power	1 x 3-pin DC power input terminal 1 x 2-pin connector for power on/of
Option	VESA Stand 4G LTE/Wi-Fi/BT
STORAGE SPACE	
HDD	1 x MO-297 SATA SSD bay (Easy Accessible)
Expansion	
Expansion Slot	1 x Internal Mini-PCIe slot full size 1 x SIM card holder / Micro SD card reader
DISPLAY	
Display Type	7" TFT-LCD
Max. Resolution	800 x 480
Max. Color	262K
Luminance (cd/m <sup>2</sup> )	350
View Angle	160(H) / 160(V)
Contrast	400:1
Backlight Lifetime	30,000 hrs
TOUCHSCREEN	
Type	Resistive Touch Projected Capacitive Touch
Interface	USB
Light Transmission(%)	Resistive Touch: over 80% Projected Capacitive Touch: over 90%
POWER	
Power Input	DC 9~36V
Power Consumption	26W

Construction	Aluminum die-casting chassis
Mounting	Panel Mount, VESA 75 x 75
IP Rating	IP66 Compliant Front Bezel
Dimensions	202 x 149 x 40 mm
Net Weight	2.8 kg
<b>ENVIRONMENTAL</b>	
Operating Temperature	0~50°C/ -20~60°C (option)
Storage Temperature	-30~70°C
Humidity	10 to 95% @ 40°C, non- condensing
Certificate	CE/FCCClassA/UL
<b>OPERATING SYSTEM SUPPORT</b>	
Windows 10 IoT	

*\*Specifications subject to change without notice, not responsible for typographical errors.*

## DIMENSION:

*This is subject to change without Notice. Final Drawings Will be Provided for Approval after Order.*

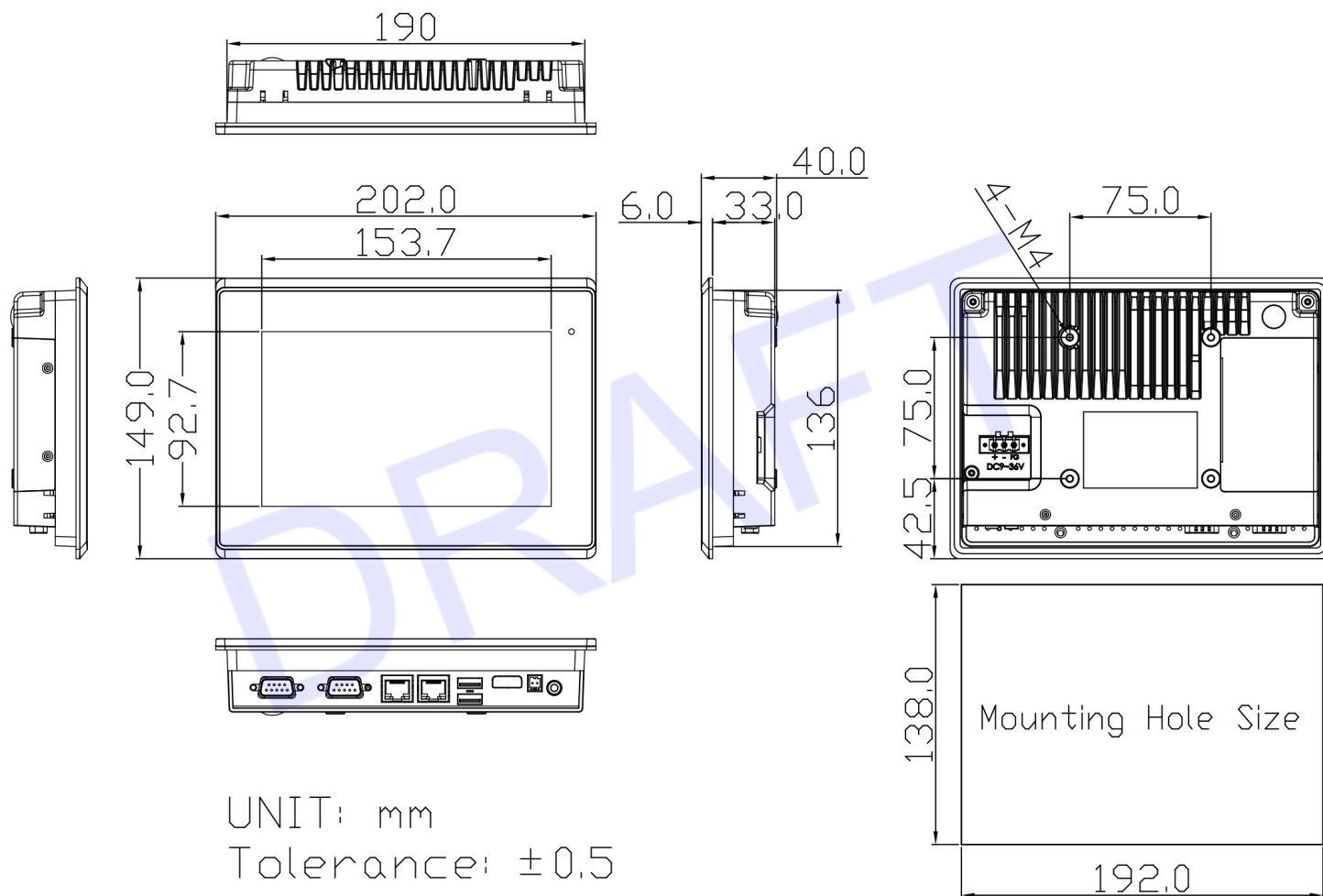

Drawing No.: APCW07N4-UL-P-V1-08152022-V1