

# MILITARY PANEL MOUNT

32" 4K LED Rugged All Aluminum Construction Panel Mount LCD IP67  
Front Face Design, 6061 T6 Milled Aluminum Front Face

Model: Dmil3200



Dmil3200 Series was designed from the ground up to meet the rugged environmental requirements. It can be built with an IP67 Front Face with IP53 Back for general rugged use or full IP67 with Mil Spec Circular Connectors for sealed applications. It comes standard with an EMI ITO Lens. It has optional Optical Bonding and also High Bright Backlit LCD Monitor, With Optional Heated Lens, and NVIS Backlight system. It was Design To Meet (DTM) many MIL Spec standards off the shelf but if you have a specific standard you need met, We can customize it to any level. It is Built from 5052H32 and 6061T6 Aluminum that is Laser Cut and Milled to a precise standard. The internal Components Can be Conformably Coated for an extra level of protection. Internal Cabling is Low Smoke Zero Halogen Teflon Cabling. Its Specifically Design for Panel Mount Applications with Milled Aluminum front face that rises only a 1/2" off its mounting surface. Exacting Precision has gone into every design feature of this unit to make it one of the best monitors in the industry, and worthy of becoming a true Military Monitor

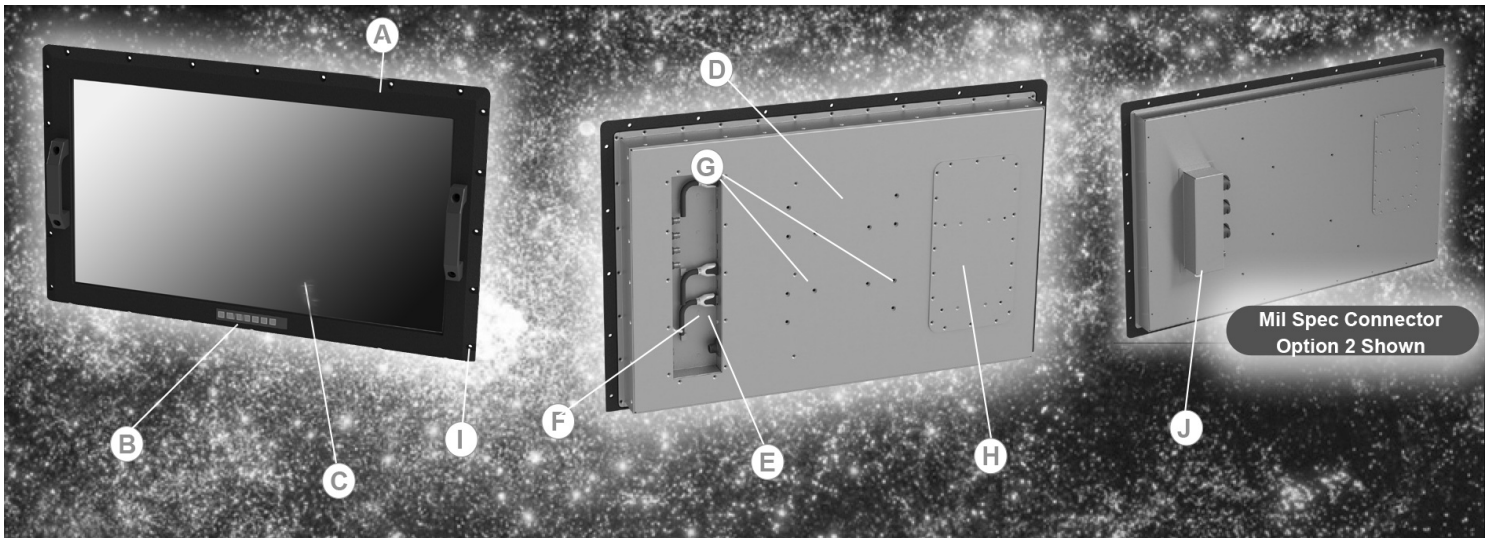

## FEATURES:

- A - Welded & Milled Aluminum Housing
- B - Water Tight OSD Menu Membrane Switches
- C - ITO Front Lens \*Optional Lens Enhancements Available
- D - Passive Cooled \*\*IP67 Optional Sealed Back Available
- E - Conformably Coated Electronics \* Multiple Coating Options to Choose From
- F - Multiple Controller Cards to Chose From Giving Flexibility to your I/O Needs.
- G - VESA Hole Positions for Expansion Modules
- H - Power Supply Plate: \*Field Serviceable Power Supply
- I - Panel Mount Hole Pattern: \*Can Be Customized to your application,
- J - IP67 Mil Spec I/O Plate: \*Customizable Inputs

## STANDARD EQUIPMENT

- Rugged All Aluminum Construction
- Includes Rear VESA Pattern for add-on equipment such as Fiber Channel
- EMI ITO Cover Glass
- IP67 Front Face Design
- 6061 T6 Milled Aluminum Front Face

## VIDEO INPUTS AVAILABLE\*

- **VGA**
- **DVI**
- **HDMI**
- **YPbPr**
- **Composite**
- **S-Video**
- **SDI**
- **Display**
- **Port**

\*Not all ports are available on all AD cards. Check I/O for each Video Controller Offered

## OPTIONS

- Multiple Lens Enhancement available Including: Heated Glass, NVIS Backlight
- High Bright Daylight Viewable option
- Optional conformal Coating
- Optional Optical Bonding for Grade A Shock
- PCAP Touch

## VIDEO CONTROLLERS

- **V38x High End 4K Controller (Production)** Max Resolution: 4096 x 2160 60Hz Input Options Available: HDMI 2.0 x1, HDMI1.4 x3, Display Port 1.2. RS-232, OSD, For command and Control, and IR Remote. Integrated Multi View (PIP, PBP, Quad View).
- Optional 3G or 6G SDI Interface can be Integrated
- **V36x Mid Grade 4K Controller (New)** Max Resolution: 4096x2160 60Hz Input Options Available: HDMI 2.0 x2, Display Port 1.2 x1, RS-232 and OSD for Command and Control. IR Remote

## LCD MODULES

### Dmil3200A - UHD 3840x2160 (Max Res)

- 32" LED Backlit LCD
- ITO EMI Lens Enhancement
- Viewing Angles: 89L/89R/89U/89D
- Contrast Ratio: 3000:1
- Brightness: 400 NITS
- Response Time: 15/5ms
- Color: 1.08B, 10 Bit
- Color Gamut: 97% NTSC
- Surface Finish: AR/AG Coated Laminated Front Lens

### Dmil3200B - UHD 3840x2160 (Max Res)

- 32" LED Backlit LCD
- ITO EMI Lens Enhancement
- Viewing Angles: 89L/89R/89U/89D
- Contrast Ratio: 3000:1
- Brightness: ~1000 NITS High Bright
- Response Time: 15/5ms
- Color: 1.08B, 10 Bit
- Color Gamut: 97%NTSC
- Surface Finish: AR/AG Coated Laminated 4mm Optically Bonded Lens

### Dmil3200C - UHD3840x2160 (Max Res)

- 32" LED Enhanced Backlit LCD
- ITO EMI Lens Enhancement
- Dual Backlight NVIS and Daylight
- Viewing Angles: 89L/89R/89U/89D
- Contrast Ratio: 3000:1
- Daylight Brightness: 400 NITS
- NVIS: B Mode
- Response Time: 15/5ms
- Color: 1.08B, 10 bit
- Color Gamut: TBD NTSC
- Surface Finish: AR/AG Optically Bonded Lens

*\*Specifications subject to change without notice, not responsible for typographical errors.*

## MIL SPECIFICATIONS

Panel can be DTM (DESIGNED TO MEET) the following Mill Standards. Full Mil Spec requirements must be disclosed during the quoting process to pick the correct components and Enhancement Process to meet your MIL Spec Requirements.

## SPECIFICATIONS

- Dimensions: 20.28" x 32.48" x 2.9"
- Weight: ~ 85 Lbs
- Power Consumption: ~130 Watts
- Shipping Weight: TBD
- Shipping Dimensions: TBD

*Values are approximate and vary based on configuration*

## Available Mil Standard DTM Options

**Operational Temperature Range:** MIL-STD-810F/G, -10C to +50C (\*Method and Procedures TBD)

**Storage Temperature:** MIL-STD-810F/G, -30C to +60C (\*Method and Procedures TBD)

**Humidity:** MIL-STD-810F/G, (\*Method and Procedures TBD)

**Altitude:** MIL-STD-810F/G, (\*Method and Procedures TBD)

**Vibration:** MIL-STD-810F/G, -167, or -516.2 (\*Method and Procedures TBD)

**Shock:** MIL-STD-810F/G, -901E Grade B, or -901E Grade A (\*Method and Procedures TBD)

**EMI:** MIL-STD-461F/G CE102, RE101, RE102, CS101, CS114, CS116, RS101, and/or RS103

*\*MIL-STD, Methods, and Procedures are based on your required needs, contact one of our knowledgeable Sales Engineers to help Spec in a unit to meet your required needs.*

# MECHANICAL DRAWINGS

This is subject to change without Notice. Final Drawings Will be Provided for Approval after Order.

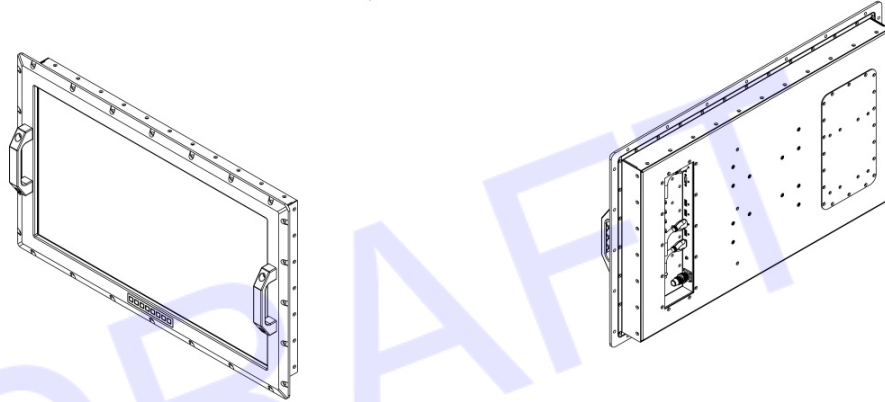
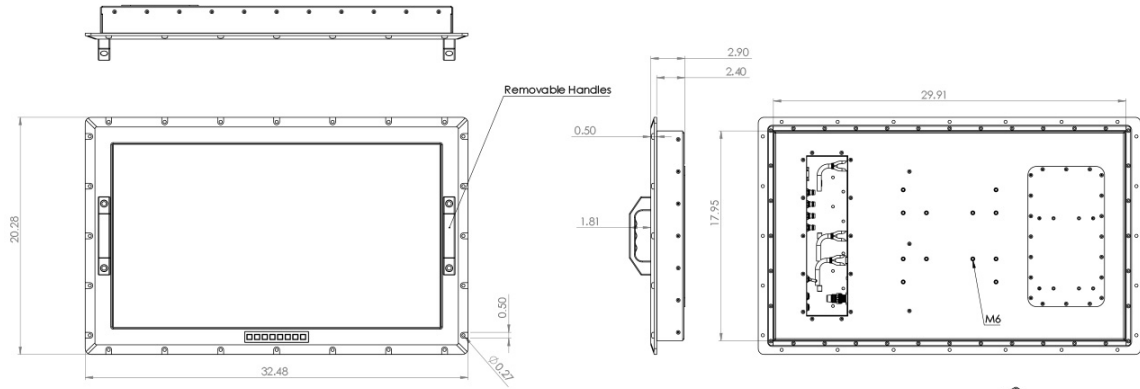

Comercial Connector Back

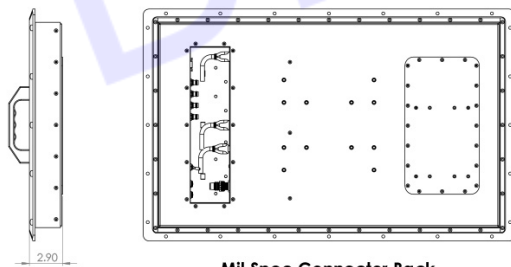

Mil Spec Connector Back

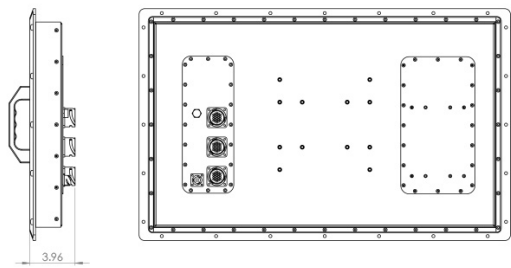

Mil Spec Connector Option 2 Back

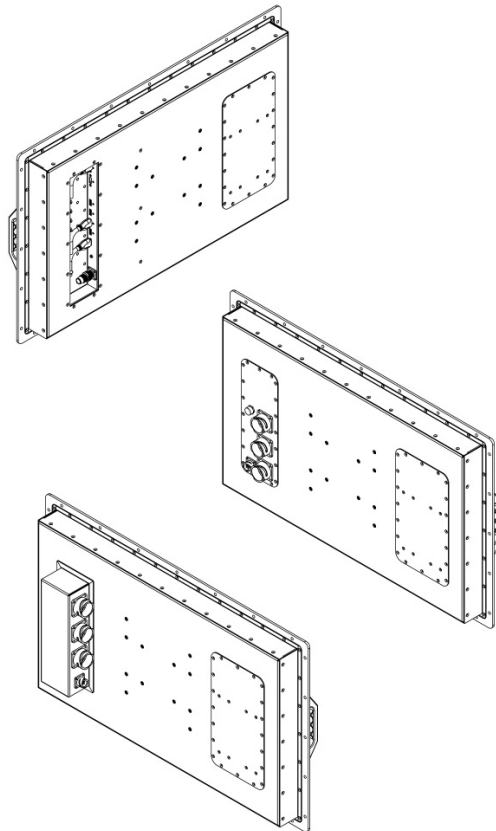
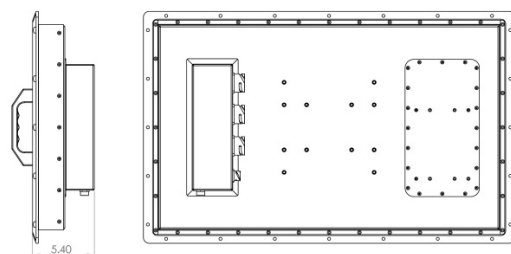

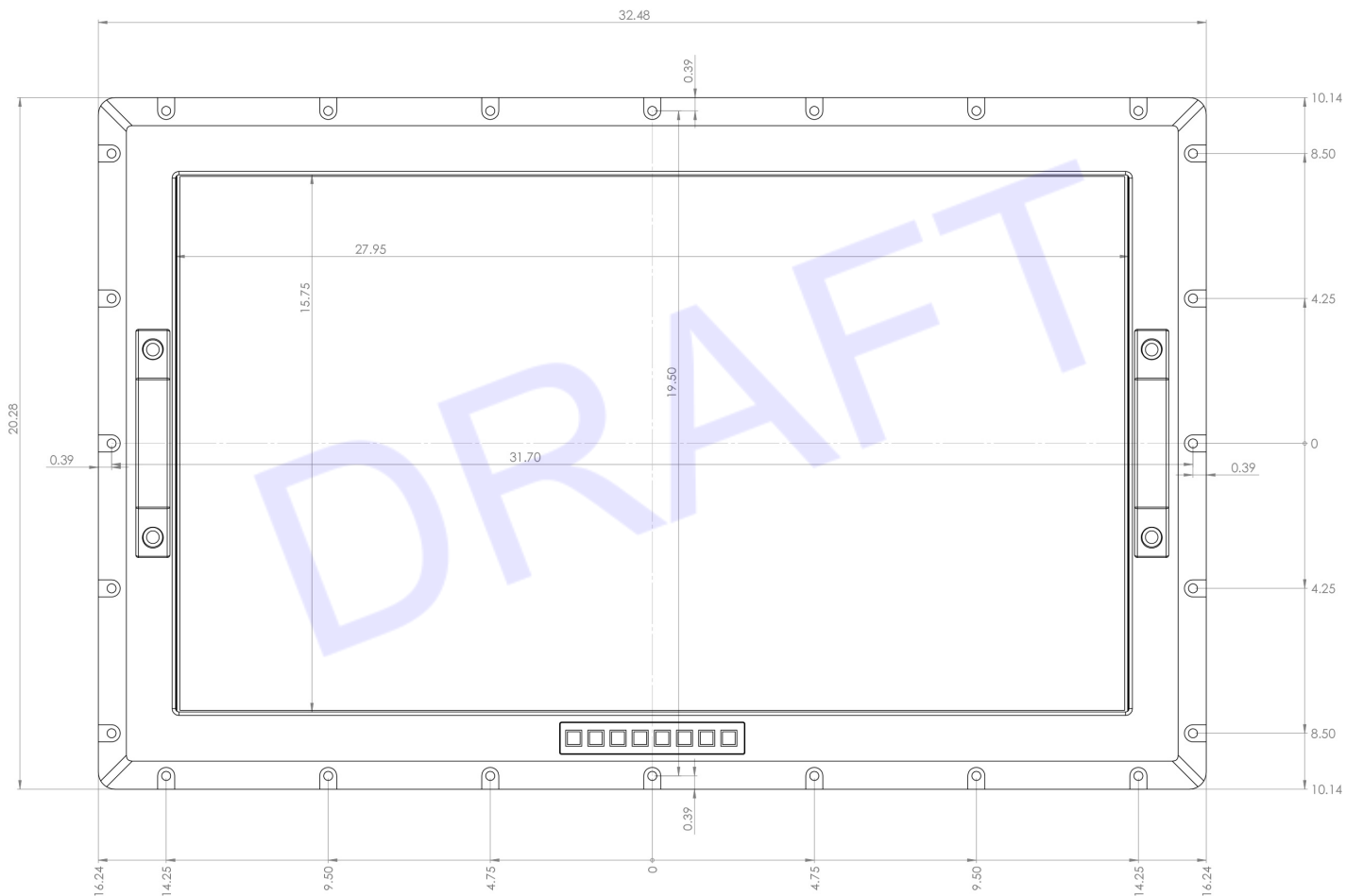

**V38x Controller**

