

FULL IP65 Stainless Steel

15" Full IP65 Stainless Steel Chassis
Fanless Touch Panel PC

Model: VPC1500SIPAM



VPC Series Full NEMA4/IP65 Water/Dust Proof All in One Stainless Steel Fanless Solutions

- Water Proof Solution, Full IP-65 Rating
- Stainless and Aluminum Housing Chassis Design
- 5-wire Resistive Touch Panel PC
- Onboard Intel® Atom™ D525 Dual-Core 1.8GHz CPU with ICH8-M Chipset
- Onboard 1GB SDRAM & 1 SODIMM Up to 3GB
- 1 Intel® 82574L Gigabit Ethernet
- 1 COM, 3 USB, 1 Membrane Power Button
- Wide Voltage +12V ~ +28V Input, ErP Power
- Over Current & Surge Protection
- Backlight Controlled by PWM/ BIOS/ API.
- Power-on Time
- Front OSD, power on/off

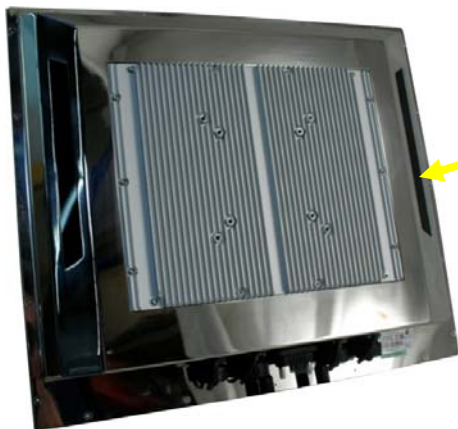
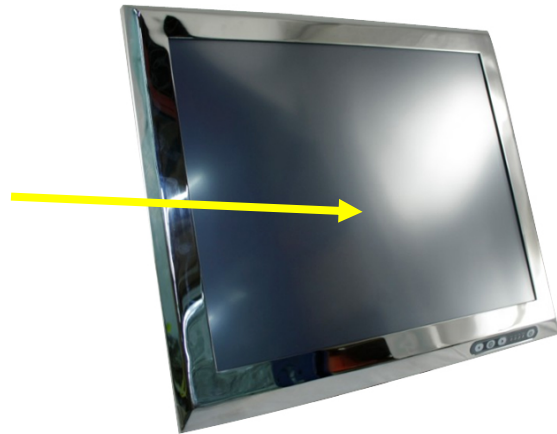

- Anti Dust Proof and Water Proof Solution,
- Full IP-65 Rating front and back.
- Stainless and Aluminum Housing Chassis Design
- VESA Mounting



- IP65 Water and Dust proof connection for a higher protection
- All Connectors are facing down, it will have you to save space





Key Features:

- Water Proof Solution, Full IP-65 Rating
- Stainless and Aluminum Housings Chassis Design
- AMD eOntario T40E 1.0 GHz CPU
- 1 Gigabit Ethernet, 1 COM, 3 USB
- 1 Membrane Power Button
- Wide Voltage +12V ~ +28V Input, ErP Power
- Power-on Timer

Intel®
AMD

GbE

1 COM

3 USB

Touch
Screen

Wide
Voltage

Fanless

Full
IP65

Specifications:

Model	VPC1500SIPAM
• LCD Size	15", 4:3
• Resolution	1024 x 768, XGA
• Pixel Pitch	0.297mm (H) x 0.297mm (V)
• Luminance	300cd/m2
• Contrast Ratio	700
• Viewing Angle	65 (U), 60 (D), 70 (L), 70 (R)
• Response Time	8ms
• Backlight	CCFL
• Touch Screen	5-wire Resistive
• Light Transmission	80%
• Touch Interface	USB

Rear I/O	
• Serial Port	1 x RS-232 (Water Proof, IP-67 Rating)
• Ethernet	1 x RJ-45 (Water Proof, IP-67 Rating) (Realtek RTL8111E Ethernet, Supports Wake on LAN)
• USB	3 x USB 2.0 (Water Proof, IP-67 Rating)
• Power Switch	1 x Membrane Power Button
• Power Input	1 x DC-in (Water Proof, IP-67 Rating)

System	
• Board	EBM-A50M
• CPU	Onboard AMD eOntario T40E 1.0GHz CPU
• System Chipset	AMD A50M Chipset
• I/O Chip	Nuvoton W83627DHG-P
• System Memory	Onboard 2GB DDR3 and One 204-pin SODIMM Supports Up to 4GB DDR3 1066MHz SDRAM
• SSD	One CF Socket by IDE Secondary Slave Channel Supports Type I/II Compact Flash Card
• Hard Driver Bay	One 2.5" SATA HDD
• Watchdog Timer	Reset: 1sec. ~ 255min. and 1sec. or 1min./step
• H/W Status Monitor	Monitoring System Temperature, Voltage, and Cooling Fan Status. with Auto Throttling Control
• Expansion	2 x Mini PCIe Slot

Model: VPC1700SIPAT



Diagram:

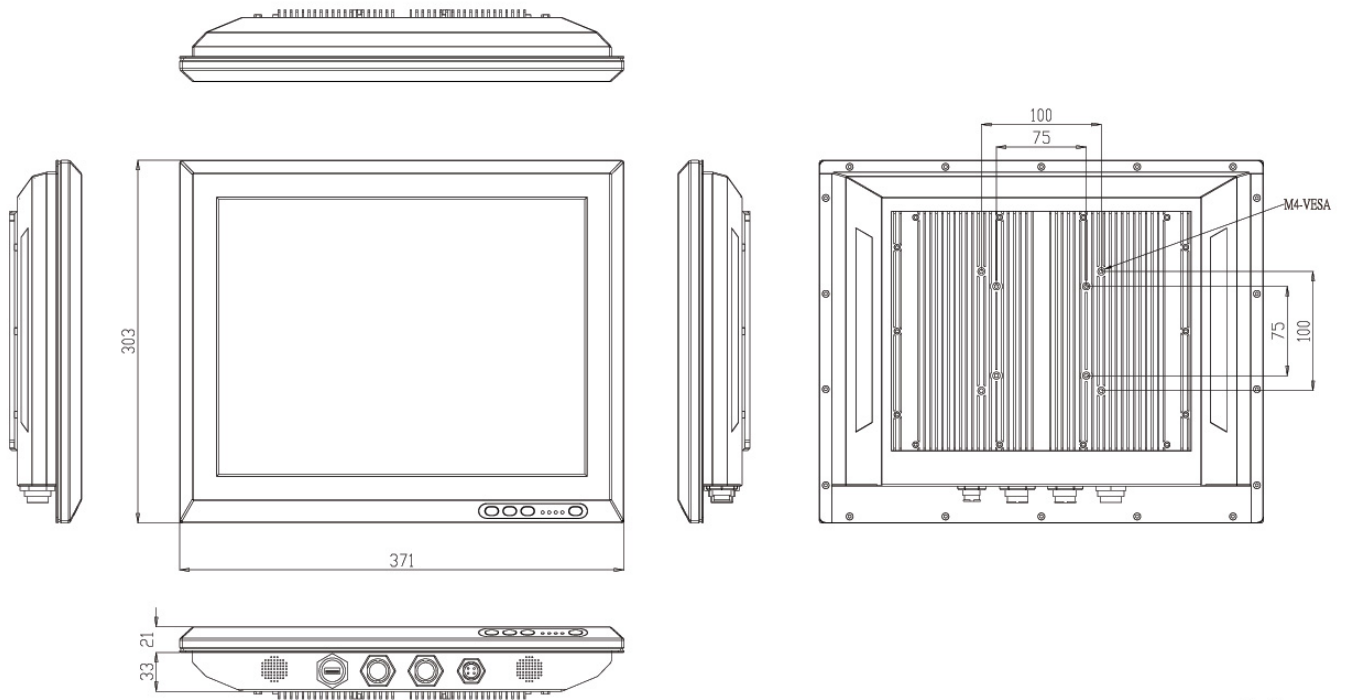

Unit: mm

Environment & Mechanical	
• Color	Front & Rear Panel Silver
• Mounting	VESA/ Wall/ Stand 75mm x 75mm & 100mm x 100mm
• System Power Requirement	+12 ~ 28V DC Power Input
• Power Adapter	Input: 100 ~ 250VAC/ 47 ~ 63Hz Output: 60W Adapter (12V @ 5A Adapter)
• Operating Temperature	0 ~ 40°C (32 ~ 104°F)
• Storage Temperature	-20 ~ 60°C (-4 ~ 140°F)
• Relative Humidity	5% ~ 90% Relative Humidity, Non-condensing
• Dimensions (W x D x H)	371mm x 303mm x 60mm
• Weight	6.42Kgs