

VPC0800CD

Fanless 8" SVGA TFT
Multifunctional Touch Panel PC

Touch
Screen

CF

2 COM

4 USB

Wide
Voltage

Fanless

VESA

IP-65



Key Features:

- 8" SVGA TFT Touch Panel PC
- 5-wire Resistive Touch Screen
- Intel® Atom™ D525 Dual-Core 1.8GHz CPU
- VGA/ HDMI, Audio
- Gigabit Ethernet, Optional WiFi Module
- 1 CF, 2 COM, 4 USB, No HDD Support
- Wide Range Voltage Input +10V ~ +28V
- Fanless, VESA Compliance
- IP-65 Compliant Front Panel

Specifications:

Model	VPC0800CD
• LCD Size	8"
• Display Type	SVGA TFT
• Resolution	800 x 600
• Pixel Pitch	0.0675mm (H) x 0.2025mm (V)
• Luminance	500cd/m ²
• Contrast Ratio	500:1
• Viewing Angle	50 (U), 70 (D), 70 (L), 70 (R)
• Response Time	25ms
• Backlight	LED
• Touch Screen	5-wire Resistive
• Light Transmission	80%
• Touch Interface	USB
System	
• Board	ECM-PNV
• CPU	Onboard Intel® Atom™ D525 Dual Core 1.8GHz CPU
• System Chipset	Intel® ICH8-M
• I/O Chip	Nuvoton W83627DHG-P
• System Memory	One 204-pin SODIMM Socket Supports Up to 2GB DDR3 800MHz SDRAM
• SSD	One Type I/II Compact Flash Card
Rear I/O	
• Serial Port	1 x RS-232, 1 x RS-232/422/485
• Ethernet	1 x RJ-45 (Intel® 82574L Gigabit Ethernet, Optional Dual 82574L Gigabit Ethernet)
• WiFi	Optional USB WiFi 802.11 b/g (Occupy One USB Port)
• VGA	1 x DB-15
• Audio	Line-out
• USB	4 x USB 2.0



Diagram:

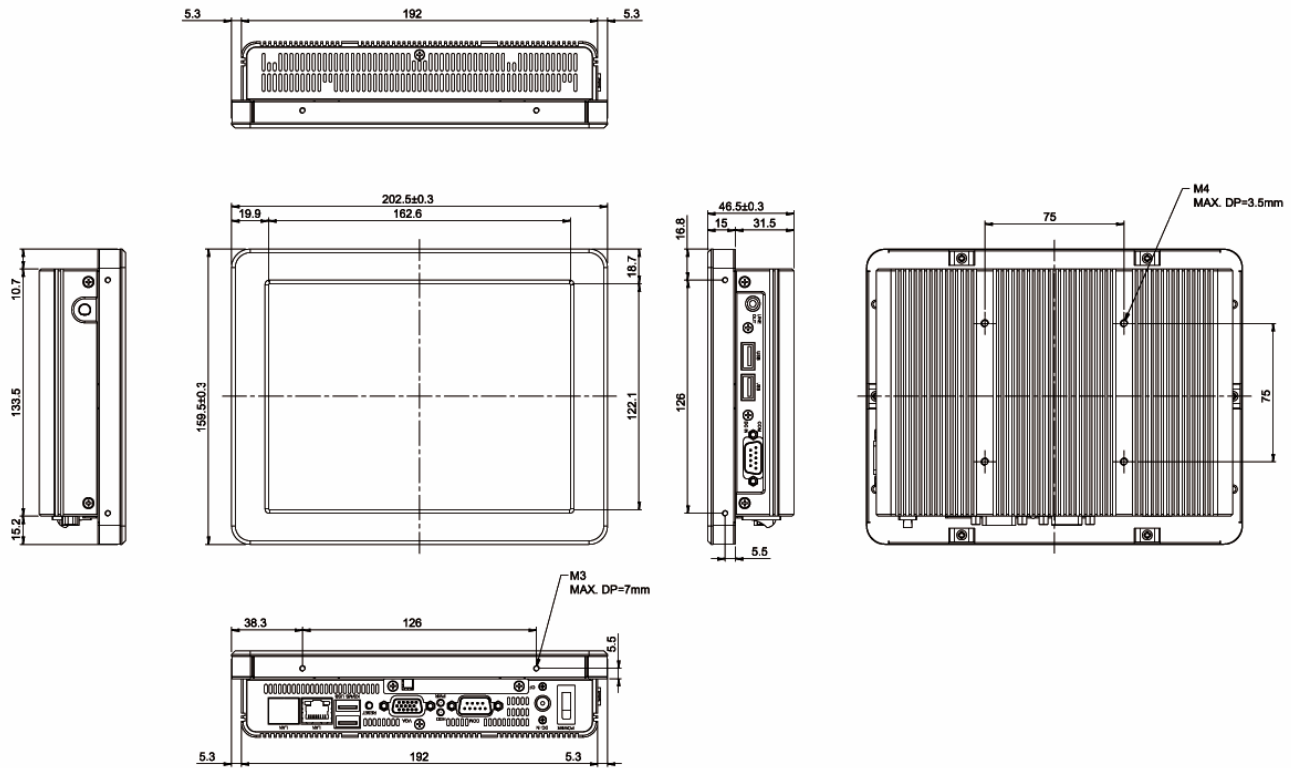

Unit: mm

Environment & Mechanical	
• Color	Front Panel Silver; Rear Body Black
• Mounting	Wall Mount/ Stand; VESA 75mm x 75mm
• System Power Requirement	+12 ~ +28V DC Power Input
• Power Adapter	Input: 100 ~ 250VAC/ 47 ~ 63Hz Output: 60W Adapter (12V @ 5A Adapter)
• Operating Temperature	0°C ~ 40°C (32 ~ 104°F)
• Storage Temperature	-20°C ~ 60°C (-4°F ~ 140°F)
• Relative Humidity	10 to 95% @ 40°C, Non-condensing
• Dimensions (W x D x H)	202.5mm x 159.5mm x 46.5mm
• Weight	1.5Kgs

