

VMPC1500AT

Fanless 15" TFT Multifunctional Touch Panel PC

Atom™

Intel®
945GSE

5.1-CH
Audio

2W
AMP

DVI-A

Mini
PCIe

4 USB

IP-65

Fanless



Key Features:

- Onboard Intel® Atom™ N270 1.6GHz CPU
- Intel® 945GSE/ ICH7-M Chipset
- One 200-pin SODIMM Up to 2GB DDR2 400/ 533 SDRAM
- 5.1-CH Audio, 1 Ethernet, 2W Amplifier
- 4 USB, 1 DVI-A, and Mini PCIe
- Support 2.5" SATA HDD
- Single +19V, Fanless Operation
- IP-65 Compliant Front Panel

Specifications:

Model	VMPC1500AT
• LCD Size	15", 4:3
• Resolution	1024 x 768 XGA
• Pixel Pitch	0.264mm (H) x 0.264mm (V)
• Luminance	350cd/m ²
• Contrast Ratio	400:1
• Viewing Angle	60 (U), 55 (D), 60 (L), 50 (R)
• Response Time	16ms
• Backlight	CCFL
• Touch Screen	5-wire Resistive
• Light Transmission	80%
• Touch Interface	USB
System	
• CPU	Intel® Atom™ N270 1.6GHz CPU
• BIOS	Award 1024KB Flash BIOS
• System Chipset	Intel® 945GSE/ ICH7-M
• I/O Chip	Winbond W83627HG-AW
• System Memory	One 200-pin SODIMM Socket Supports Up to 2GB DDR2 400/ 533 SDRAM
• Hard Drive Bay	One 2.5" SATA HDD
• Watchdog Timer	Reset: 1sec. ~ 255 min. and 1sec. or 1min./step
• H/W Status Monitor	Monitoring System Temperature, Voltage, and Cooling Fan Status. with Auto Throttling Control
• Expansion	1 x Mini PCIe Slot
Rear I/O	
• Ethernet	1 x RJ-45 (Intel® 82574L Gigabit Ethernet, Optional Dual 82574L Gigabit Ethernet)
• VGA	1 x DVI-A
• Audio	Mic-in, Speaker-out (Realtek ALC888 Supports 5.1-CH Audio)
• USB	4 x USB 2.0
• Speaker	2 x 2W



i-Tech Company LLC
TOLL FREE: (888) 483-2418 • EMAIL: info@itechlcd.com • WEB: www.iTechLCD.com

Diagram:

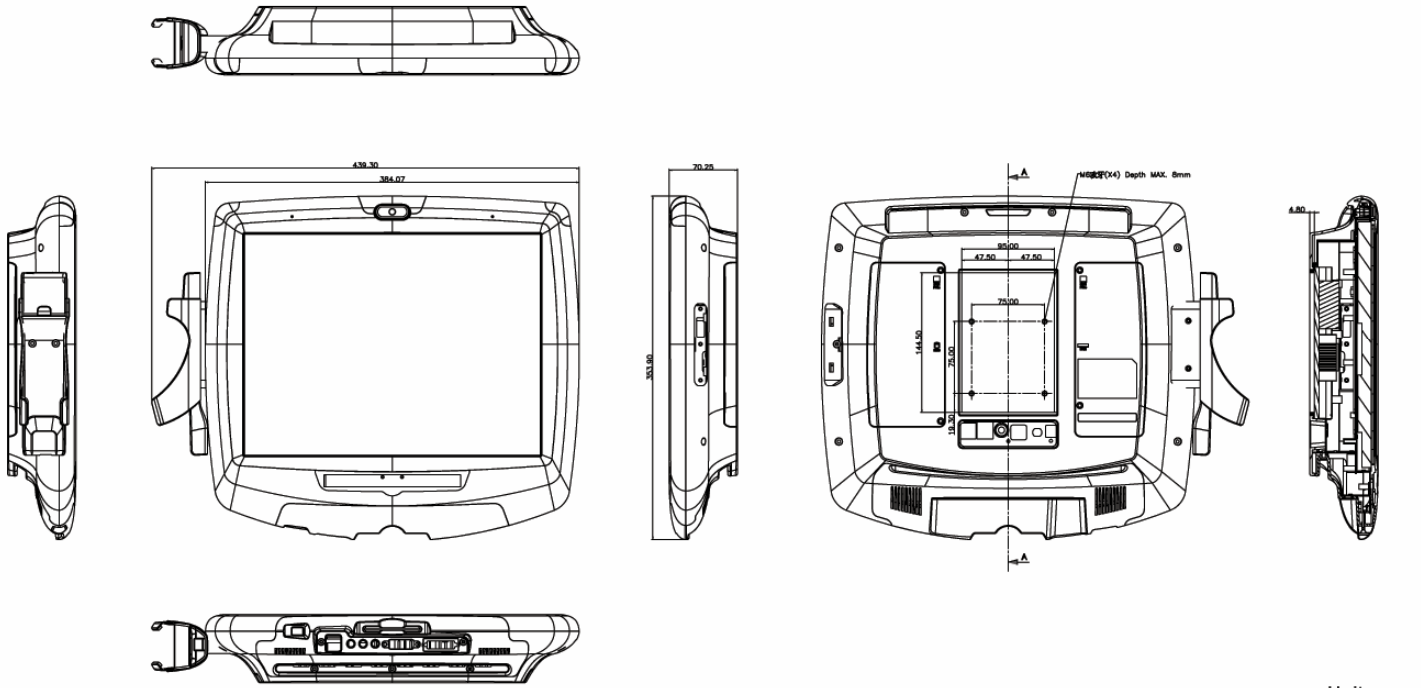

Environment & Mechanical	
• Color	Front & Rear Panel White (Plastics)
• Mounting	Wall/ Stand/ VESA 75mm x 75mm
• Power Input	100 ~ 250Vdc/ 47 ~ 63 Hz
• Power Output	+19Vdc/ 4.73A (90W)
• Power Type	AT/ ATX
• Operating Temperature	0°C ~ 40°C (32°F ~ 104°F)
• Storage Temperature	-20 ~ 60°C (-4 ~ 140°F)
• Relative Humidity	0% ~ 90% Relative Humidity, Non-condensing
• Dimensions (W x D x H)	442mm x 349mm x 70mm
• Weight	4.2Kgs

