

Fanless Front Stainless PANEL PC

19" Intel ATOM Fanless PANEL PC

True Fanless ATOM-N270 Panel PC
Easy install HDD Tray
Compact & SLIM Design

IP65 in Front & Side Frame
Anti Vibration HDD Kit

Model: PNPC1900AT

FEATURES:



■ IP65 in Front & Side Frame



■ HDD Anti-Vibration Easy-install kit



■ Ultra Slim Design

True Fanless ATOM Panel PC: Fanless, lower power consumption all in on PC with stainless steel Front bezel.

Stainless Steel Front Bezel:
Reduced dirt adhesion for easier cleaning and maintenance

Built in Speakers at the side

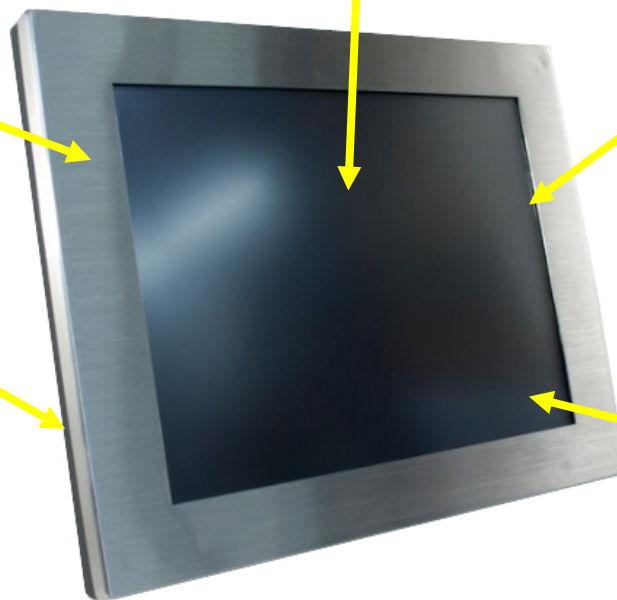

IP65/NEMA4:
Front Water and dust proof. Totally protected against dust, Protected against low pressure jets if water from all directions, limited ingress permitted

5 Wire Resistive Touch:
long life. Its durability and reliability are the features which make it enable to incorporate in heavy industry machinery, commercial markets and electronic equipment



Side Easy Access I/O:

COM3

Side ON/OFF.

LED Light



Easy Install HDD Tray:
One screw away to remove the HDD easy for access and service

VESA mounting at the back

SPECIFICATIONS:

<i>System</i>	
Motherboard Type	Intel
Form Factor	Mini ITX
System Chipset	Intel945SGE + ICH7M
CPU Supporting	Intel ATOM N270
FSB	533 MHz
DIMM Socket	DDR2 533/400 SDRAM(Up to 2GB) default 1GB
Graphic	Integrated Intel 950GMA
Audio	Realtek ALC662 6-Channel HD Audio CODEC
LAN Controller	Realtek RTL8111DL PCI-E Gigabit Ethernet LAN
I/O Connector	RJ-45 LAN × 1 / Serial port × 3(COM1 for RS-422/485) / USB Port × 4 / VGA Port × 1 PS/2 Mini DIN keyboard port & mouse port / Audio Line-in/out and Mic-in Jacks
<i>Display</i>	
Size	19"; 1280 x 1024
Contrast Ratio	800 : 1
Brightness	300cd/m ²
<i>Mechanical</i>	
Touch	Default Taiwan 5wire resistive touch
Device	default 160GB 2.5" SATA HOD
Power Supply	ADAPTER 12V/7A 84W (S-JACK-4) (RoHS)
Bezel	Stainless
Dimension	416 x 85 x 327 mm (W x D x H)
Operating Temp	0°-40°C (Fanless)
Relative Humidity	10%-90%@50°C. non-condensing
Vibration	5-17.01" double amplitude displacement. 17-640HZ.1 5G acceleration perk to perk
Shock	10-25Hz(X.Y.Z direction 2G.30 minutes)
Features	IP65 in front & side frame

Wall Mount Plate Kit:

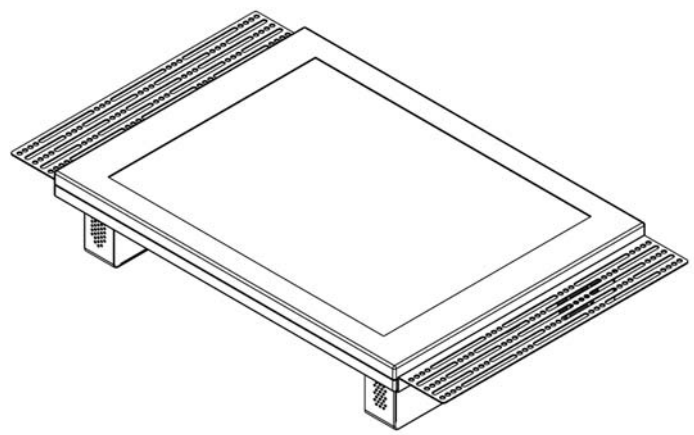
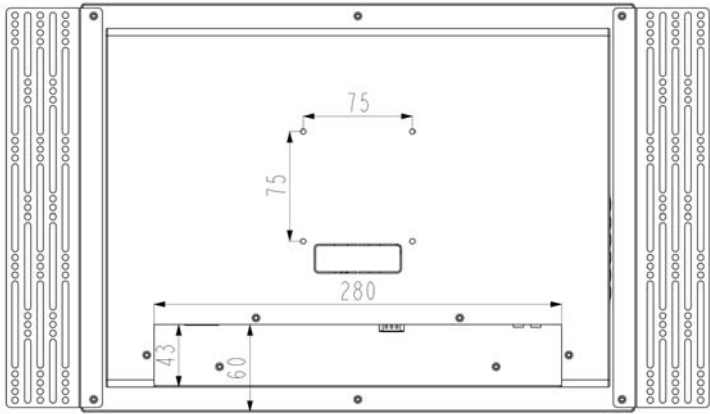
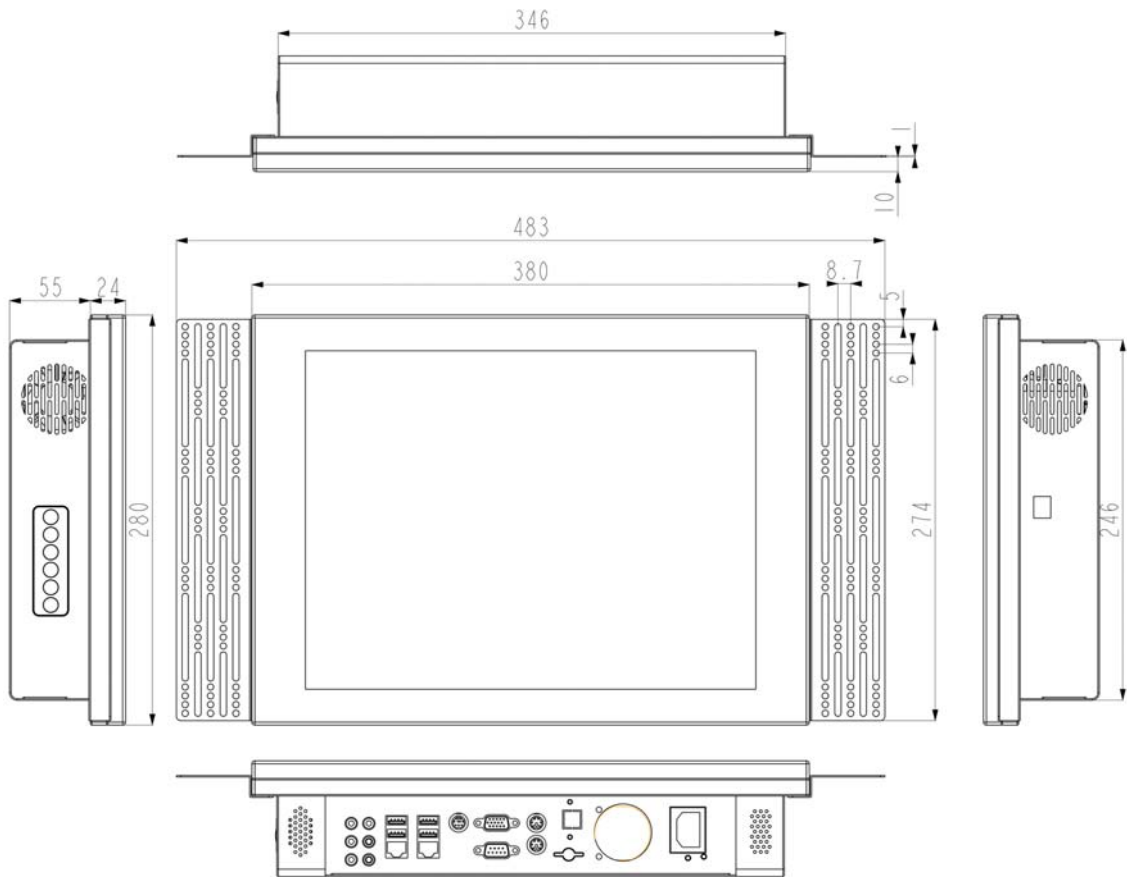

Mechanical Drawing:

