

# Fanless Front Stainless PANEL PC

## 15" Intel ATOM Fanless PANEL PC

True Fanless ATOM-N270 Panel PC  
Easy install HDD Tray  
Compact & SLIM Design

IP65 in Front & Side Frame  
Anti Vibration HDD Kit



Model: PNPC1500AT

### FEATURES:



■ IP65 in Front & Side Frame



■ HDD Anti-Vibration Easy-install kit



■ Ultra Slim Design



True Fanless ATOM Panel PC: Fanless, lower power consumption all in on PC with stainless steel Front bezel.

**Stainless Steel Front Bezel:**  
Reduced dirt adhesion for easier cleaning and maintenance

**Built in Speakers at the side**

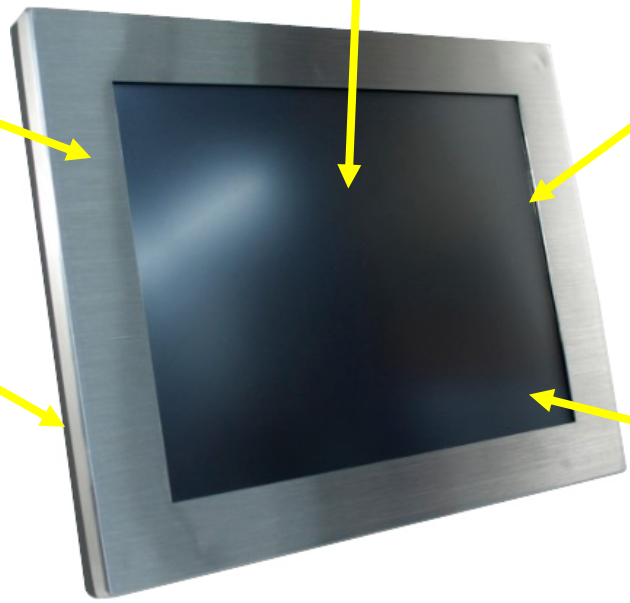

**IP65/NEMA4:**  
Front Water and dust proof. Totally protected against dust, Protected against low pressure jets if water from all directions, limited ingress permitted

**5 Wire Resistive Touch:**  
long life. Its durability and reliability are the features which make it enable to incorporate in heavy industry machinery, commercial markets and electronic equipment



**Side Easy Access I/O:**

COM3

Side ON/OFF.

LED Light



**Easy Install HDD Tray:**  
One screw away to remove the HDD easy for access and service

**VESA mounting at the back**

**SPECIFICATIONS:**

<i>System</i>	
Motherboard Type	Intel
Form Factor	Mini ITX
System Chipset	Intel945SGE + ICH7M
CPU Supporting	Intel ATOM N270
FSB	400 MHz
DIMM Socket	DDR2 RAM(Up to 2GB) default 1GB
Graphic	Integrated Intel 945GSE
Audio	Realtek ALC662 6-Channel HD Audio CODEC
LAN Controller	Realtek RTL8111DL PCI-E Gigabit Ethernet LAN
I/O Connector	RJ-45LAN* 1 /Serial port * 3( COM 1 for RS-422/485) / USB Port * 4 / VGA Port * 1 PS/2 Mini DIN keyboard port & mouse port / Audio Line-in/out and Mic-in Jacks
<i>Display</i>	
Size	15" 1024x768
Contrast Ratio	450:1
Brightness	250cd/m2
<i>Mechanical</i>	
Touch	Default Taiwan 5wire resistive touch
Device	default 160GB 2.5" SATA HOD
Power Supply	ADAPTER 12V/7A 84W (S-JACK-4) (RoHS)
Bezel	Stainless
Dimension	379.84 x 79 x 280 mm (W x D x H)
Operating Temp	0°-40°C (Fanless)
Relative Humidity	10%-90%@50°C. non-condensing
Vibration	5-17.01" double amplitude displacement. 17-640HZ.1 5G acceleration perk to perk
Shock	10-25Hz(X.Y.Z direction 2G.30 minutes)
Features	IP65 in front & side frame

## Dimensions:

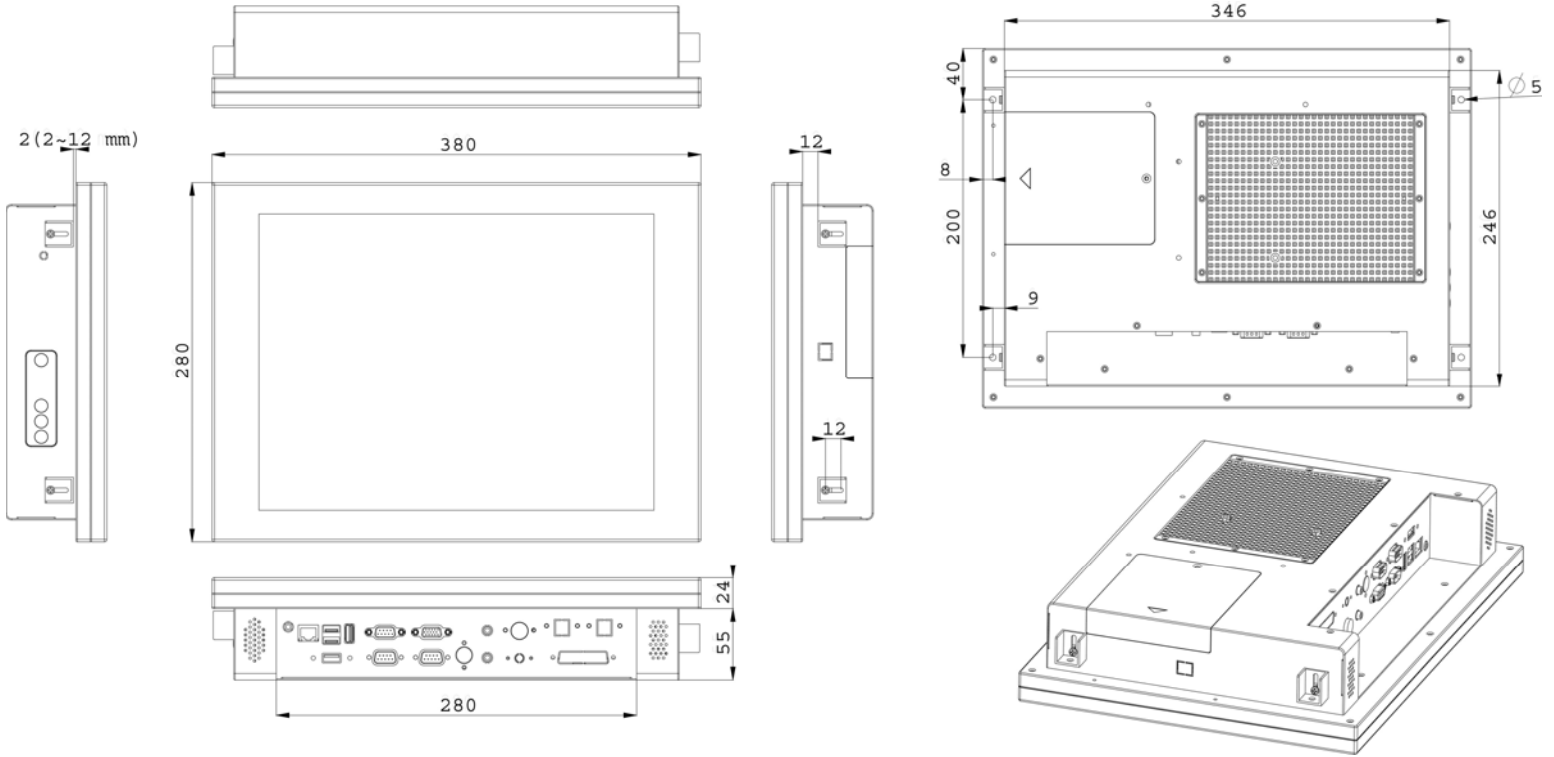

## I/O Port:

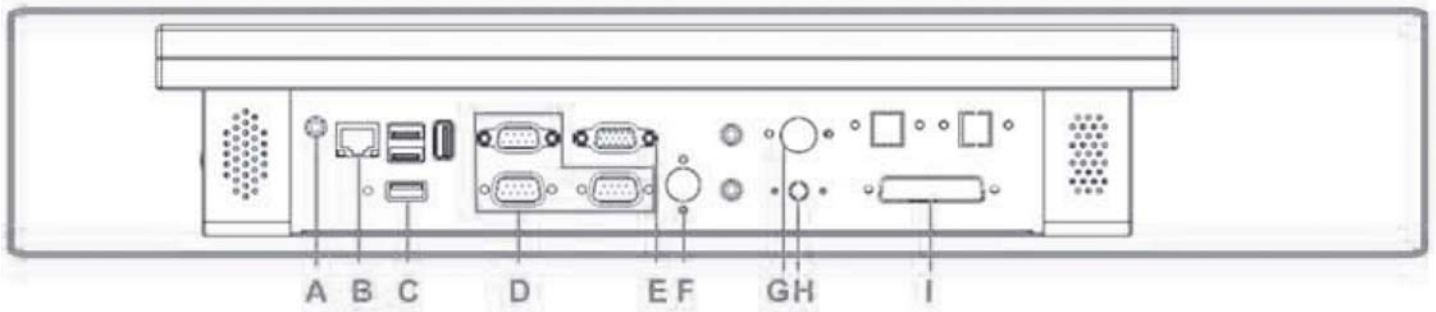

- A.** Audio Line Out/Optical SPDIF\_Out
- B.** RJ45 Gbe Ethernet
- C.** USB 2.0x4
- D.** COM port x 3

- E.** VGA port
- F.** PS/2 mouse and keyboard port
- G.** 4 Pin 12V DC in
- H.** 12V DC in
- I.** Parallel Port

## Wall Mount Plate Kit:

