

Fanless Front Stainless PANEL PC

High Brightness 1600nits

12" Intel ATOM Fanless PANEL PC

True Fanless ATOM-N270 Panel PC
Easy install HDD Tray
Compact & SLIM Design

IP65 in Front & Side Frame
Anti Vibration HDD Kit

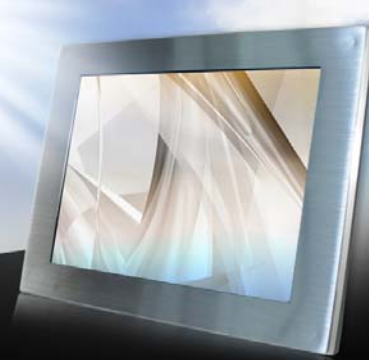

Model: **PNPC1210HBAT**

FEATURES:



■ IP65 in Front & Side Frame



■ True Fanless Design



■ Ultra Slim Design

True Fanless ATOM Panel PC: Fanless, lower power consumption all in on PC with stainless steel Front bezel.

Stainless Steel Front Bezel:
Reduced dirt adhesion for easier cleaning and maintenance

Built in Speakers at the side

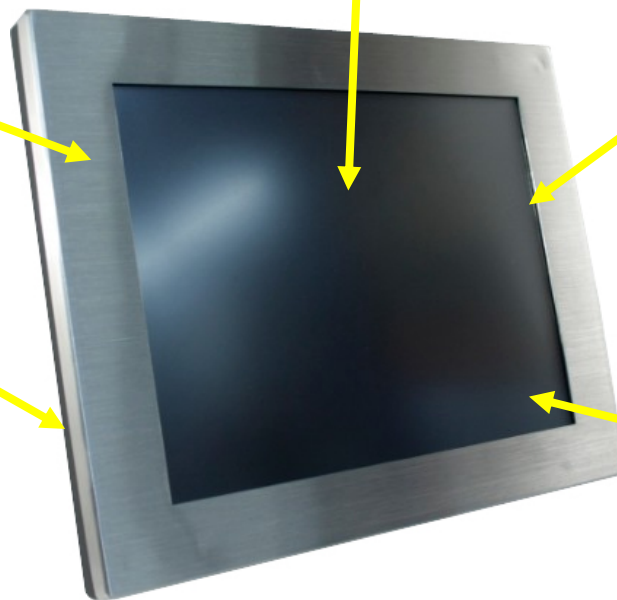

IP65/NEMA4:
Front Water and dust proof. Totally protected against dust, Protected against low pressure jets if water from all directions, limited ingress permitted

5 Wire Resistive Touch:
long life. Its durability and reliability are the features which make it enable to incorporate in heavy industry machinery, commercial markets and electronic equipment



i-Tech Company LLC
TOLL FREE: (888) 483-2418 • EMAIL: info@iTechLCD.com • WEB: www.iTechLCD.com

Side Easy Access I/O:

- COM3
- Side ON/OFF.
- LED Light



Easy Install HDD Tray:
One screw away to remove the HDD easy for access and service

VESA mounting at the back

SPECIFICATIONS:

<i>System</i>	
Motherboard Type	Intel
Form Factor	Mini ITX
System Chipset	Intel945SGE + ICH7M
CPU Supporting	Intel ATOM N270
FSB	400 MHz
DIMM Socket	DDR2 RAM(Up to 2GB) default 1GB
Graphic	Integrated Intel 945GSE
Audio	Realtek ALC662 6-Channel HD Audio CODEC
LAN Controller	Realtek RTL8111DL PCI-E Gigabit Ethernet LAN
I/O Connector	RJ-45 LAN * 1 / Serial port * 3(COM1 (or RS-422/485) / USB Port * 4 / VGA Port * 1 PS/2 Mini DIN keyboard port & mouse port / Audio Line-irt/out and Mic-in Jacks

<i>Display</i>	
Size	12" 1024x768
Contrast Ratio	400:1
Brightness	1600cd/m2

<i>Mechanical</i>	
Touch	Default Taiwan 5wire resistive touch
Device	default 160GB 2.5" SATA HOD
Power Supply	ADAPTER 12V/7A 84W (S-JACK-4) (RoHS)
Bezel	Stainless
Dimension	326 x 76.05 x 252 mm (W x D x H)
Operating Temp	0°-40°C (Fanless)
Relative Humidity	10%-90%@50°C. non-condensing
Vibration	5-17.01" double amplitude displacement. 17-640HZ.1 5G acceleration perk to perk
Shock	10-25Hz(X.Y.Z direction 2G.30 minutes)
Features	IP65 in front & side frame



Dimensions:

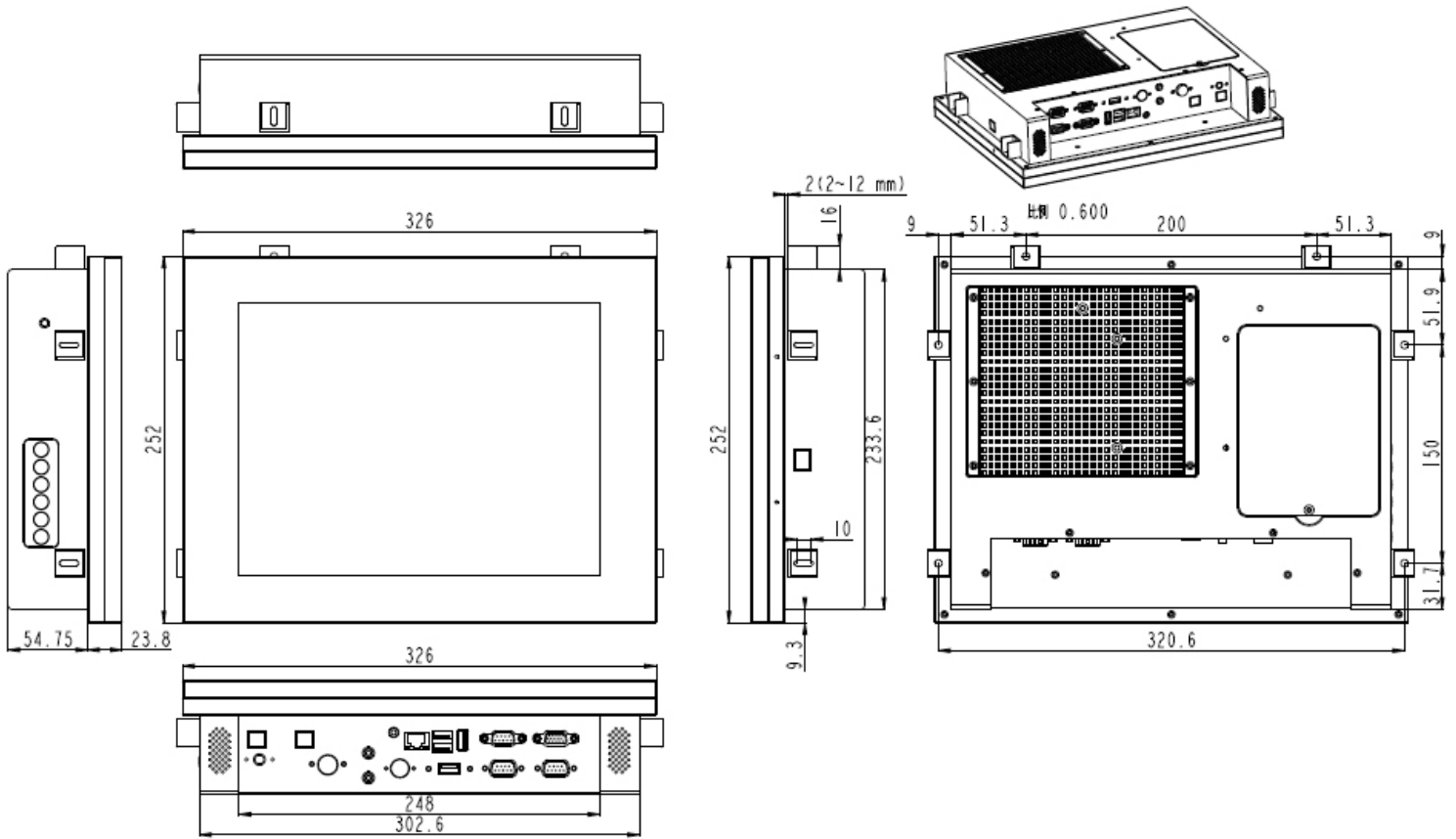

I/O Port:

- A. Audio Line Out/Optical SPDIF_Out
- B. RJ45 Gbe Ethernet
- C. USB 2.0x4
- D. COM port x 3

- E. VGA port
- F. PS/2 mouse and keyboard port
- G. 4 Pin 12V DC in
- H. 12V DC in
- I. Parallel Port

Wall Mount Plate Kit:

