

32" Outdoor LCD GS3200HDL1



32" All Weather Outdoor Sunlight Readable LCD
1500 nits 1920 x 1080, 2000:1 with Strength Safety 6mm glass
(Landscape mode). IP65/NEMA4 All Weather proof Enclosures
with thermal control with Air- conditioning and Heater thermal
control Video input: HDMI, VGA, DVI

Overview:

Suntronic's GS product line, featuring innovative All-Weather Sunlight Readable LCD technology, provides the highest-quality Sunlight Readable image available in Out Door Environment. These Industrial grade Outdoor displays have the exemplary resolution and brightness you've come to expect from Suntronic. GS technology delivers stunning images for use in applications such as: Digital Signage, Ski Resorts, Retail/ Restaurants, Golf Course, Gas Stations, Shopping Malls, Restaurants and Outdoor

Features Highlight:

- 1500 nits High-Brightness LCD Panel
- All Weather Proof IP65 Enclosures
- Operating Temperature -40F To 122F*
- Integrated heater and air conditioner
- Vandal Resistant Screen & housing
- Unique Front Access Design
- Remote Reboot/Temp. & Humidity Monitoring available (Optional)
- Wireless and VGA/DVI CAT5 signal extenders available (Optional)

Technical specifications

Active area size (W x H): 32" (697.7 x 392. mm)

Panel resolution (pixels): 1920 x 1080

Luminance of white (Brightness): 1500 nits (Typ)

Contrast ratio: 1500:1

Response time (gtg): 8 ms (Typ)

Colour Range: 16.7 Million colours (max)

Viewing angle: 85/85/85/85

Video inputs: VGA; DVI, HDMI

Auto Brightness Control: Yes (Optional)

Front glass type: Strengthen 6mm AR glass

IP Class: IP65

Operating temperature range: -40 to + 95F (Direct Sunlight) /122F (Under Shaded Area)

Storage Temperature: 0 to 50C

CCFL Life Time: 60K hrs (min)

Input voltage: 110V

Weight: 150lbs

External dimensions (W x H x D): 34"W x 23.7H x 11.5" D mm Notes: to guarantee a proper functionality, 6" of clearance must be kept around the display

Portrait version: Please contact SuntronicLCD for details

Options

1. Integrated CAT5/Fiber Optics VGA/DVI Extenders
2. Custom Embedded PCs and Wireless
3. Serial RS232 Input
4. Screen Sensor/Environmental Sensors
5. Auto Brightness Control Sensors

Customization: Integrated with Third Party Media player,

Customization: Please contact SuntronicLCD for available options



Pictures:



High Quality Parts

Our company uses only the best, using only High Quality parts along with components in USA or imported from Korea, Taiwan and Germany, for quality that you can trust!



Customer Service

Our customer service reps are here to help you with your Outdoor LCD sign. From general questions to technical support, we leave you feeling completely satisfied.



US Manufactured

Our Outdoor LCD Signs are assembled, tested and shipped from our very own factory, giving us the ability to customize signs to your



Mechanical Drawings:

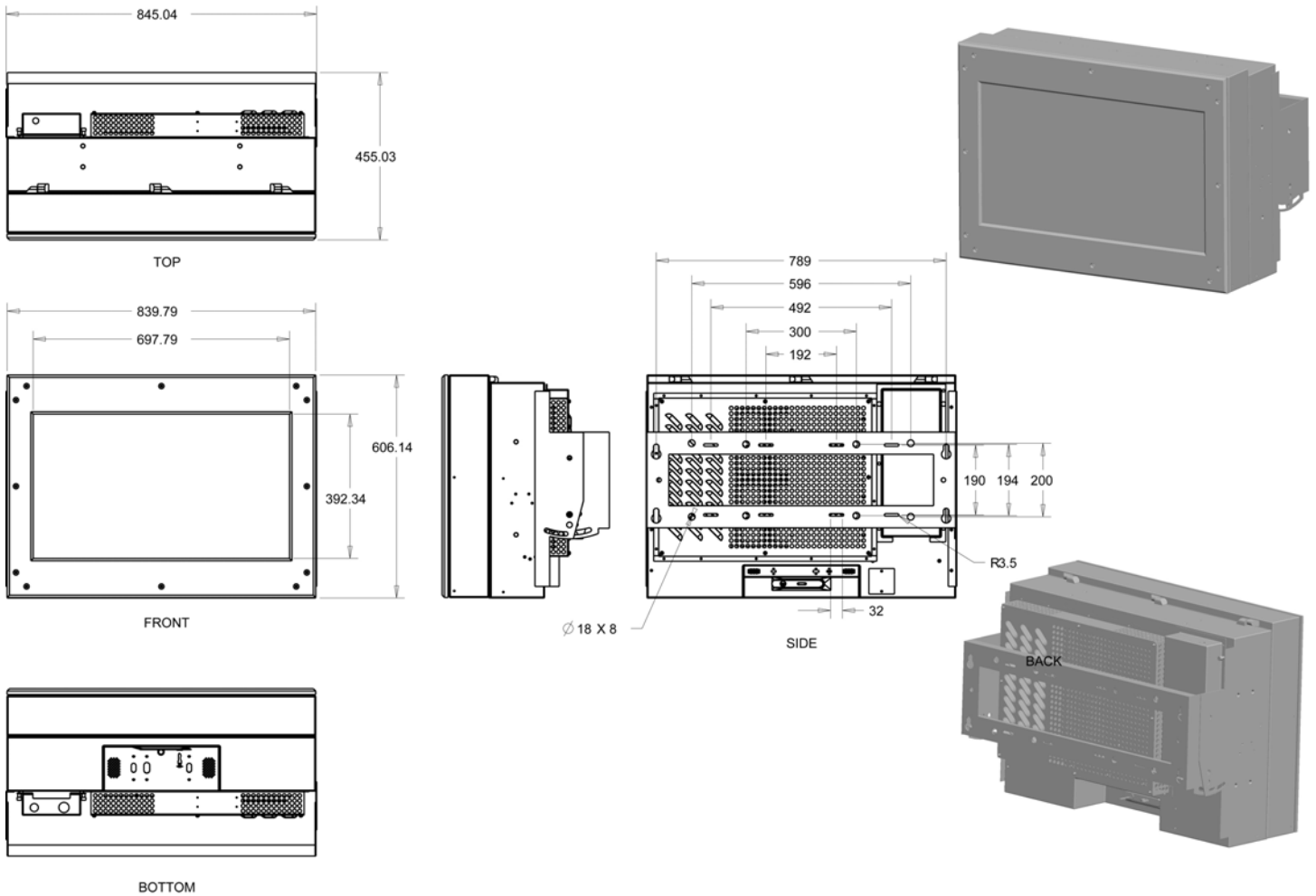

High Quality Parts

Our company uses only the best, using only High Quality parts along with components in USA or imported from Korea, Taiwan and Germany, for quality that you can trust!



Customer Service

Our customer service reps are here to help you with your Outdoor LCD sign. From general questions to technical support, we leave you feeling completely satisfied.



US Manufactured

Our Outdoor LCD Signs are assembled, tested and shipped from our very own factory, giving us the ability to customize signs to your

