

Fanless Slim Medical Panel PC Series Solutions

Fanless Medical Graded Slim All-in-One C2D 1.06GHz.17" LCD.2GB RAM. 160GB HD.2 Isolated USB.Isolated RS232.Gigabit LAN. XP Pro. Medical Graded AntiMicrobial (Washerable) Keyboard & Mouse(Optional).DC9-30V.

Model: AMPC1700S-C2D

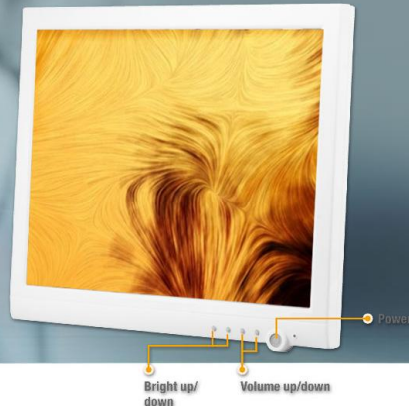

FEATURES

- Intel® Core™ 2 Duo ULV Processor / Celeron® Mobile Processor
- 17" SXGA Color TFT LCD Display
- COM Isolation
- Fanless, Zero Noise
- Easy To Use, Compact, Simple Design
- 1000 : 1 Contrast Wide View Angle For X-Ray Film
- Resistive Touchscreen (Optional)
- 802.11a/b/g/n Wireless Antenna (Optional)
- CE/FCC Class B, EN/UL60601-1 Medical Certification

SPECIFICATIONS

Main System	
Processor	Intel® Core™ 2 Duo ULV 1.06 GHz (U7500) / Celeron® M 1.86GHz (440)
System Memory	DDRII SODIMM supports DDRII 400/533 up to 2 GB (optional)
Chipset	Intel® 945 GME + ICH7M
OS Support	Windows® XP, XP Pro, XPE, WES, WES 7, Windows® 7
Expansion	Mini-PCI x 1
Storage Disk Drive	2.5" SATA Hard Disk Drive x 1 , Internal CFD x 1
Display	
Size	17"
Resolution	1280 x 1024
Max. Colors	16.7M
Luminance	380 nits
Dot Size	0.264mm x 0.264mm
View Angle	170° (H)/170° (V)
Contrast Ratio	1000 : 1
Back Light MTBF (Hours)	50,000 Hours
Touch Screen	5-wire Resistive/ 2048 x 2048, 35 million activities
I/O	
Audio	Mic in/ Line out
USB	USB 2.0 x 4 (for A1 model) / USB 2.0 x 6 (for A3 model)
Serial Port	RS-232 x 1 (for A3 model) RS-232/422/485 x 1, RS-232 Isolation x1 (Optional) (for A1 model)
Ethernet	Isolated Gigabit LAN X 1
VGA Port	D-Sub, 9 Pin
Keyboard & Mouse	PS/2 Keyboard / Mouse x1
Speaker	2W x 2
Mechanical and Environment	
Power Requirement	DC 9 ~ 30V
Operating Temperature	32°F ~ 104°F (0°C ~ 40°C)
Storage Temperature	-4°F ~ 140°F (-20°C ~ 60°C)
Mounting	VESA 75/100
Net Weight	12.32 lb (5.6 kg)
EMC	CE/FCC Class B, UL 60601-1, EN 60601-1



MECHANICAL DRAWING

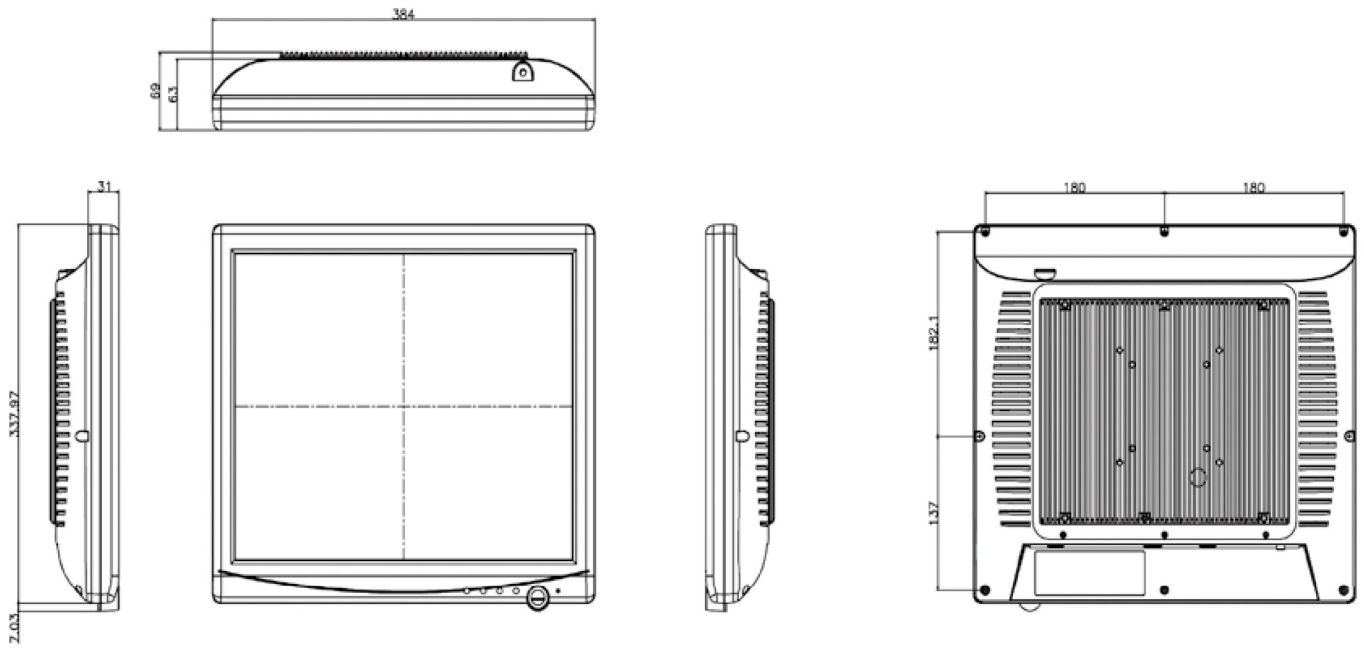

DT(T)-A1

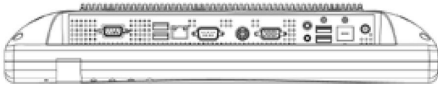

SD(T)-A1



DT(T)-A3

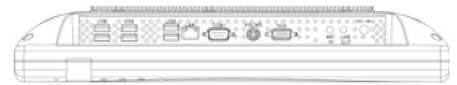

OPTIONS

- (TF) Wireless LAN kit. Mini PCI. IEEE 802. 11a/b/g. With internal cable. antenna. For wistron CM9-GP